

Jaipur Institute of Technology Group of Institutions

/ Jaipur - Near Mahindra SEZ Kalwara, Ajmer Road



LAB-MANUAL

3rd SEM EE

Circuit lab

C
i
r
c
u
i
t
E
l
e
c
t
r
i
c
a
l
c
i
r
c
u
i
t
l
a
b

INDEX

S. No.	List of Experiments	Page No.
1	Verification of Kirchhoff's current law and voltage law using hard ware and digital simulation.	6
2	Verification of mesh analysis using hard ware and digital simulation.	10
3	Verification of nodal analysis using hard ware and digital simulation.	13
4	Determination of average value, rms value, form factor, peak factor of sinusoidal wave, square wave using hard ware and digital simulation.	16
5	Verification of super position theorem using hard ware and digital simulation.	20
6	Verification of reciprocity theorem using hardware and digital simulation.	23
7	Verification of maximum power transfer theorem using hardware and digital simulation	27
8	Verification of Thevenin's theorem using hard ware and digital simulation	30
9	Verification of Norton's theorem using hard ware and digital simulation	34

10	Verification of compensation theorem using hard ware and digital simulation	37
11	Verification of Milliman's theorem using hard ware and digital simulation	41
12	Verification of series resonance using hard ware and digital simulation	45
13	Verification of parallel resonance using hard ware and digital simulation	51
14	Verification of self inductance and mutual inductance by using hard ware	57

ATTAINMENT OF PROGRAM OUTCOMES & PROGRAM SPECIFIC OUTCOMES

Exp. No.	Experiment	Program Outcomes Attained	Program Specific Outcomes Attained
1	Verification of Kirchhoff's current law and voltage law using hard ware and digital simulation.	PO1,PO5	PSO2
2	Verification of mesh analysis using hard ware and digital simulation.	PO1,PO2,PO5	PSO2
3	Verification of nodal analysis using hard ware and digital simulation.	PO1,PO2,PO5	PSO2
4	Determination of average value, rms value, form factor, peak factor of sinusoidal wave, square wave using hard ware and digital simulation.	PO4,PO5	PSO2
5	Verification of super position theorem using hard ware and digital simulation.	PO1,PO2,PO5	PSO2
6	Verification of reciprocity theorem using hardware and digital simulation.	PO1,PO2,PO5	PSO2
7	Verification of maximum power transfer theorem using hardware and digital simulation	PO2,PO3,PO5	PSO2
8	Verification of Thevenin's theorem using hard ware and digital simulation	PO2,PO3,PO5	PSO2
9	Verification of Norton's theorem using hard ware and digital simulation	PO2,PO3,PO5	PSO2
10	Verification of compensation theorem using hard ware and digital simulation	PO2,PO3,PO4,PO5	PSO2
11	Verification of Milliman's theorem using hard ware and digital simulation	PO2,PO3,PO4,PO5	PSO2
12	Verification of series resonance using hard ware and digital simulation	PO3,PO4,PO5	PSO2
13	Verification of parallel resonance using hard ware and digital simulation	PO3,PO4	PSO2
14	Verification of self inductance and mutual inductance by using hard ware	PO1,PO3,PO4	PSO2

ELECTRICAL CIRCUITS LABORATORY

OBJECTIVE:

The objective of the Electrical Circuits lab is to expose the students to the of electrical circuits and give them experimental skill. The purpose of lab experiment is to continue to build circuit construction skills using different circuit element. It also aims to introduce MATLAB a circuit simulation software tool. It enables the students to gain sufficient knowledge on the programming and simulation of Electrical circuits,

OUTCOMES:

Upon the completion of Electrical Circuit and simulation practical course, the student will be able to attain the following:

- 1 Familiarity with DC and AC circuit analysis techniques.
- 2 Analyze complicated circuits using different network theorems.
- 3 Acquire skills of using MATLAB software for electrical circuit studies.
- 4 Determine the self and mutual inductance of coupled coils.

EXPERIMENT - 1

(A) VERIFICATION OF KVL AND KCL

1.1 AIM:

To verify Kirchoff's Voltage Law (KVL) and Kirchoff's Current Law (KCL) in a Passive Resistive Network .

1.2 APPARATUS:

S. No	Apparatus Name	Range	Type	Quantity
1	RPS			
2	Ammeter			
3	Voltmeter			
4	Resistors			
5	Bread Board	-	-	01
6	Connecting Wires	-	-	As required

1.3 CIRCUIT DIAGRAMS:

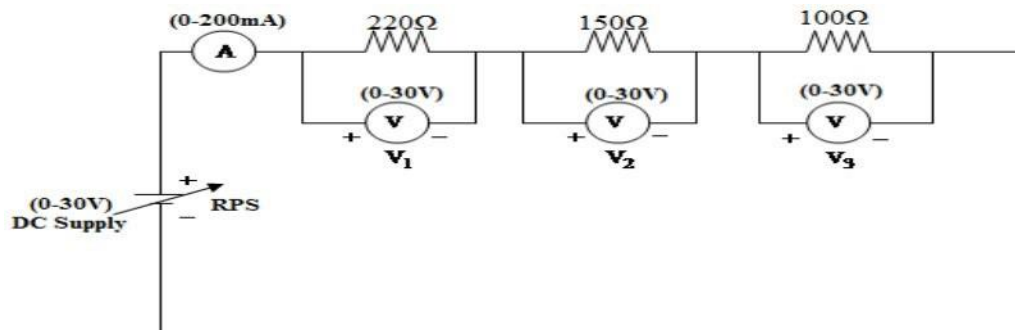

Figure – 1.1 Verification of KVL

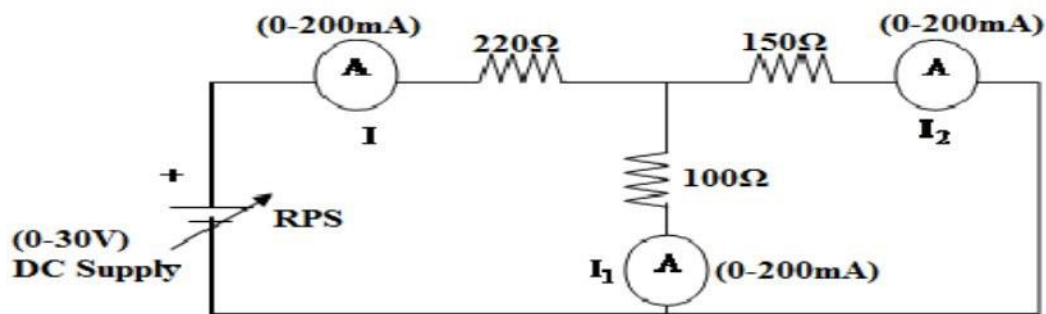

Figure – 1.2 Verification of KCL

1.4 PROCEDURE:

To Verify KVL

1. Connect the circuit diagram as shown in Figure 1.
2. Switch ON the supply to RPS.
3. Apply the voltage (say 5v) and note the voltmeter readings.
4. Gradually increase the supply voltage in steps.
5. Note the readings of voltmeters.
6. sum up the voltmeter readings (voltage drops) , that should be equal to applied voltage .
7. Thus KVL is Verified practically.

To Verify KCL

1. Connect the circuit diagram as shown in Figure 2.
2. Switch ON the supply to RPS.
3. Apply the voltage (say 5v) and note the Ammeter readings.
4. Gradually increase the supply voltage in steps.
5. Note the readings of Ammeters.
6. Sum up the Ammeter readings (I_1 and I_2) , that should be equal to total current (I).
7. Thus KCL is Verified practically

1.5 OBSERVATIONS:

For KVL

Applied Voltage V (volts)	V_1 (volts)		V_2 (volts)		V_3 (volts)		$V_1+V_2+V_3$ (volts)	
	Theoretical	Practical	Theoretical	Practical	Theoretical	Practical	Theoretical	Practical

For KCL

Applied Voltage V (volts)	I(A)		I_1 (A)		I_2 (A)		I_1+I_2 (A)	
	Theoretical	Practical	Theoretical	Practical	Theoretical	Practical	Theoretical	Practical

1.6 PRECAUTIONS:

1. Check for proper connections before switching ON the supply
2. Make sure of proper color coding of resistors
3. The terminal of the resistance should be properly connected.

1.7 RESULT:

(B) VERIFICATION OF KVL AND KCL USING DIGITAL SIMULATION.

1.8 AIM:

To verify Kirchoff's Voltage Law (KVL) and Kirchoff's Current Law (KCL) using digital simulation.

1.9 APPARATUS:

S. No	SOFTWARE USED	DESK TOP QUANTITY
1	MATLAB	01

1.10 CIRCUIT DIAGRAMS:

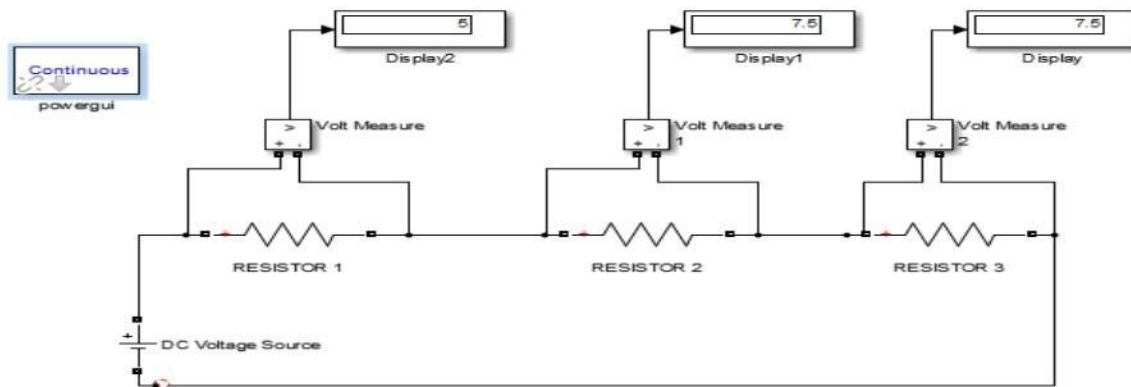

Figure – 1.3 Verification of KVL

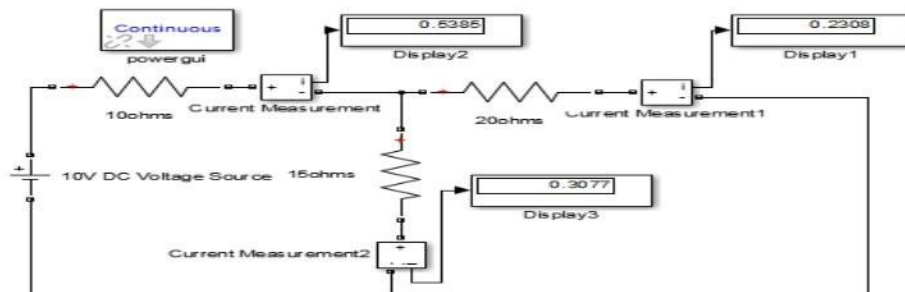

Figure – 1.4 Verification of KCL

1.11 PROCEDURE:

1. Make the connections as shown in the circuit diagram by using MATLAB Simulink.
2. Measure the voltages and currents in each resistor.
3. Verify the KVL and KCL.

1.12 OBSERVATIONS:**For KVL**

Applied Voltage V (volts)	V ₁ (volts)		V ₂ (volts)		V ₃ (volts)		V ₁ +V ₂ +V ₃ (volts)	
	Theoretical	Practical	Theoretical	Practical	Theoretical	Practical	Theoretical	Practical

For KCL

Applied Voltage V (volts)	I(A)		I ₁ (A)		I ₂ (A)		I ₁ +I ₂ (A)	
	Theoretical	Practical	Theoretical	Practical	Theoretical	Practical	Theoretical	Practical

1.13 RESULT:**1.14 PRE LAB VIVA QUESTIONS:**

1. Define current.
2. Define voltage.
3. What is resistance?
4. Define ohm's law.
5. State KCL and KVL.

1.15 POST LAB VIVA QUESTIONS:

1. What do you mean by junction?
2. Derive current division rule.
3. Explain the sign conventions.
4. Explain the color coding of resistors.

EXPERIMENT - 2**(A) MESH ANALYSIS****2.1 AIM**

The study of mesh analysis is the objective of this exercise, specifically its usage in multi-source DC circuits. Its application in finding circuit currents and voltages will be investigated.

2.2 APPARATUS:

S.No.	Equipment	Range	Type	Quantity
1.	Resistors	-	-	
2.	Ammeter			
3.	R.P.S			
4.	Bread Board	-	-	
5.	Connecting Wires			required

2.3 THEORY:

Multi-source DC circuits may be analyzed using a mesh current technique. The process involves identifying a minimum number of small loops such that every component exists in at least one loop. KVL is then applied to each loop. The loop currents are referred to as mesh currents as each current interlocks or meshes with the surrounding loop currents. As a result there will be a set of simultaneous equations created, an unknown mesh current for each loop. Once the mesh currents are determined, various branch currents and component voltages may be derived.

2.4 CIRCUIT DIAGRAM:

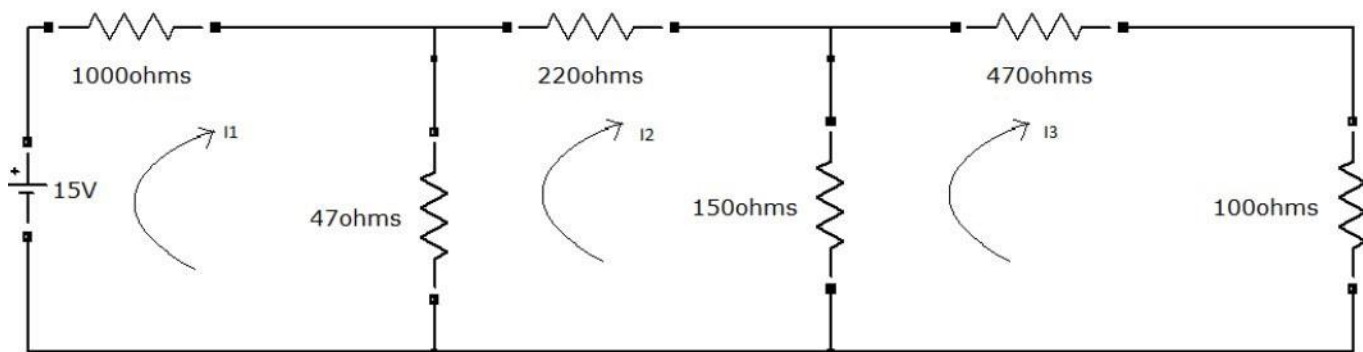

Figure – 2.1 Mesh analyses

2.5 PROCEDURE

1. Connect the circuit diagram as shown in Figure 2.1.
2. Switch ON the supply to RPS.
3. Apply the voltage (say 15v).
4. Gradually increase the supply voltage in steps.
5. Connect ammeters in the loop and find the currents I_1 , I_2 and I_3 .
6. Verify the practical results obtained with theoretical results

2.6 OBSERVATIONS:

Applied Voltage V (volts)	Loop current(I ₁)		Loop current (I ₂)		Loop current(I ₃)	
	Theoretical	Practical	Theoretical	Practical	Theoretical	Practical

2.7 PRECAUTIONS:

1. Check for proper connections before switching ON the supply
2. Make sure of proper color coding of resistors
3. The terminal of the resistance should be properly connected.

2.8 RESULT:

(B) MESH ANALYSIS USING DIGITAL SIMULATION

AIM:

To verify mesh analysis using digital simulation.

2.9 APPARATUS:

S. No	SOFTWARE USED	DESKTOP QUANTITY
1	MATLAB	01

2.10 SIMULATION DIAGRAMS:

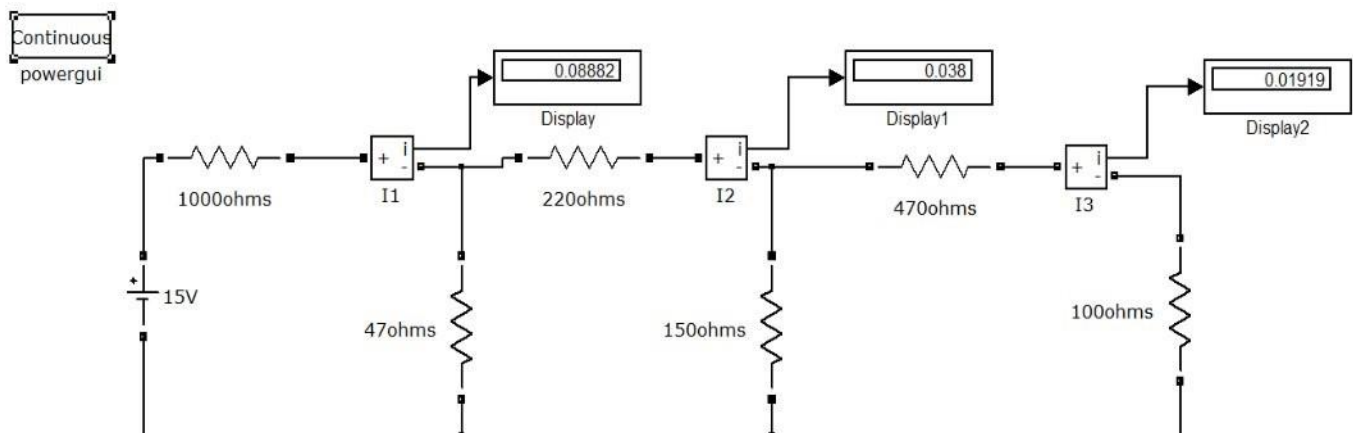

Figure – 2.2 Mesh analysis in MATLAB

2.11 PROCEDURE:

1. Make the connections as shown in the circuit diagram by using MATLAB Simulink.
2. Measure current in each resistor.
3. Verify the mesh analysis.

2.12 OBSERVATIONS:

Applied Voltage V (volts)	Loop current(I ₁)		Loop current (I ₂)		Loop current(I ₃)	
	Theoretical	Practical	Theoretical	Practical	Theoretical	Practical

2.13 RESULT

2.14 PRE LAB VIVA QUESTIONS:

1. On which law is the mesh analysis based?
2. What is mesh analysis?
3. When do we go for super mesh analysis?
4. What is the equation for determining the number of independent loop equations in mesh current method?

2.15 POST LAB VIVA QUESTIONS:

1. How do we calculate branch currents from loop currents?
2. How do we calculate branch voltages from loop currents?

EXPERIMENT - 3

(A) NODAL ANALYSIS

3.1 AIM

The study of nodal analysis is the objective of this exercise, specifically its usage in multi-source DC circuits. Its application in finding circuit node voltages will be investigated.

3.2 APPARATUS:

S.No.	Equipment	Range	Type	Quantity
1.	Resistors	-	-	
2.	Voltmeter			

3.	R.P.S			
4.	Bread Board	-	-	
5.	Connecting Wires			required

3.3 THEORY:

In electric circuits analysis, nodal analysis, node-voltage analysis, or the branch current method is a method of determining the voltage (potential difference) between "nodes" (points where elements or branches connect) in an electrical circuit in terms of the branch currents.

3.4 CIRCUIT DIAGRAM:

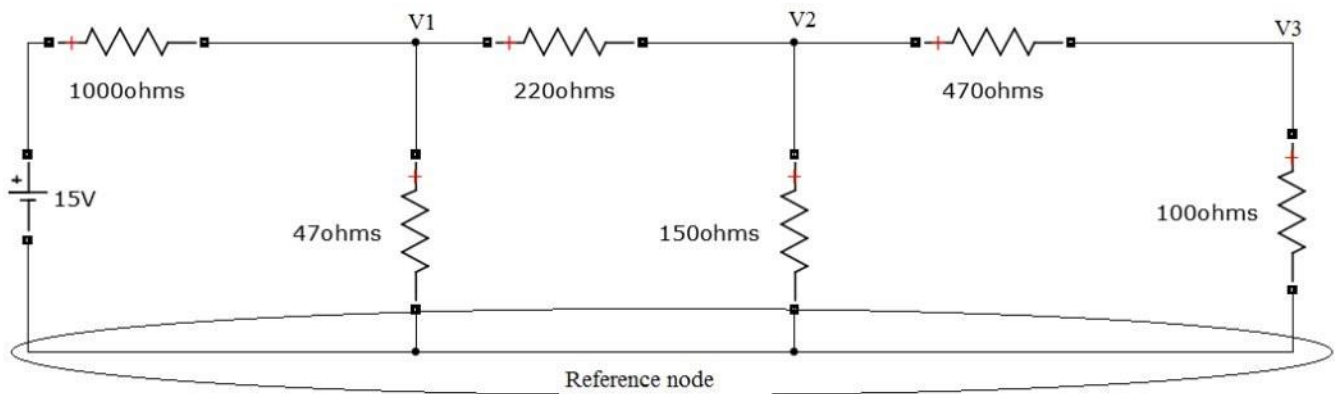

Figure – 3.1 Nodal analysis

3.5 PROCEDURE

1. Connect the circuit diagram as shown in Figure 3.1.
2. Switch ON the supply to RPS.
3. Apply the voltage (say 15v) and note the voltmeter readings.
4. Gradually increase the supply voltage in steps.
5. Note the readings of voltmeters.
6. Verify the practical results obtained with theoretical results.

3.6 OBSERVATIONS:

Applied Voltage V (volts)	Node voltage(v ₁)		Node voltage(v ₂)		Node voltage(v ₃)	
	Theoretical	Practical	Theoretical	Practical	Theoretical	Practical

3.7 PRECAUTIONS:

1. Check for proper connections before switching ON the supply
2. Make sure of proper color coding of resistors
3. The terminal of the resistance should be properly connected.

3.8 RESULT

(B) NODAL ANALYSIS USING DIGITAL SIMULATION

3.9 AIM:

To verify nodal analysis using digital simulation.

3.10 APPARATUS:

S. No	SOFTWARE USED	DESKTOP QUANTITY
1	MATLAB	01

3.11 SIMULATION DIAGRAMS:

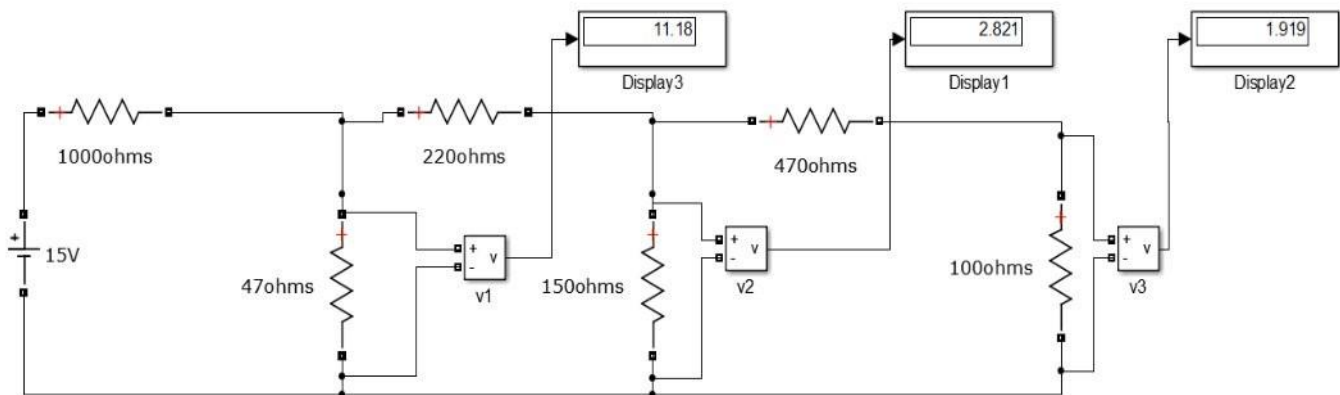

Figure – 3.2 Nodal analysis in MATLAB

3.12 PROCEDURE:

1. Make the connections as shown in the circuit diagram by using MATLAB Simulink.
2. Measure the voltage across each node using voltage measurement.
3. Verify with the theoretical results obtained with practical results

3.13 OBSERVATIONS:

Applied Voltage V (volts)	Node voltage (V_1)		Node voltage (V_2)		Node voltage (V_3)	
	Theoretical	Practical	Theoretical	Practical	Theoretical	Practical

--	--	--	--	--	--	--

3.14 RESULT:

3.15 PRE LAB VIVA QUESTIONS:

1. On which law is the nodal analysis based?
2. What is nodal analysis?
3. When do we, go for super-node analysis?

3.16 POST LAB VIVA QUESTIONS:

1. Define node.
2. Is nodal analysis is applicable to both dc and ac supply?
3. How do we calculate branch currents from node voltages?
4. How do we calculate branch voltages from node voltages?

EXPERIMENT - 4

AVERAGE VALUE, RMS VALUE, FORM FACTOR, PEAK FACTOR OF SINUSOIDAL WAVE, SQUARE WAVE

4.1 AIM:

To determine the average value, RMS value, form factor, peak factor of sinusoidal wave, square wave.

4.2 APPARATUS

S. No	Name	Range	Quantity
1	Resistors	100Ω	2 Nos
2	Inductor	1 mH	1 No
3	Function Generator		1 No
4	Multimeter		1 No
5	CRO		1 No

4.3 THEORY:

In alternating current (AC, also ac) the movement (or flow) of electric charge periodically reverses direction. An electric charge would for instance move forward, then backward, then forward, then backward, over and over again. In direct current (DC), the movement (or flow) of electric charge is only in one direction.

Average value: Average value of an alternating quantity is expressed as the ratio of area covered by wave form to distance of the wave form.

Root Mean Square (RMS) Value: The RMS value of an alternating current is expressed by that steady DC current which when flowing through a given circuit for given time produces same heat as produced by that AC through the same circuit for the same time period. In the common case of alternating current when $I(t)$ is a sinusoidal current, as is approximately true for mains power, the RMS value is easy to calculate from the continuous case equation above. If we define I_p to be the peak current, then in general form

$$I_{\text{RMS}} = \sqrt{\frac{1}{T_2 - T_1} \int_{T_1}^{T_2} (I_p \sin(\omega t))^2 dt}$$

Where t is time and ω is the angular frequency ($\omega = 2\pi/T$, where T is the period of the wave).

For a sinusoidal voltage,

$$V_{\text{rms}} = \frac{V_{\text{peak}}}{\sqrt{2}}$$

The factor is called the crest factor, which varies for different waveforms. For a triangle wave form centered about zero.

$$V_{\text{rms}} = \frac{V_{\text{peak}}}{\sqrt{3}}$$

For a square wave form centered about zero

RMS (Root Mean Square) value of an ac wave is the mean of the root of the square of the voltages at different instants. For an ac wave it will be $1/\sqrt{2}$ times the peak value.

4.4 CIRCUIT DIAGRAM:

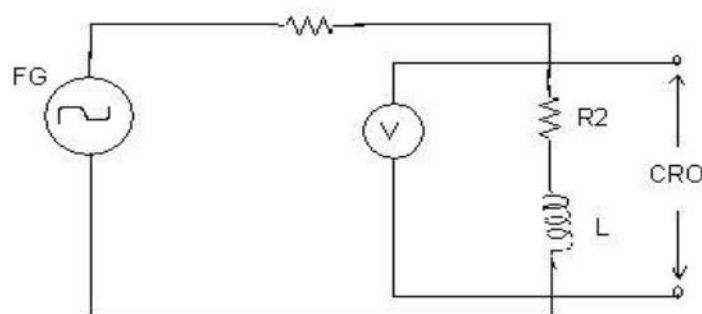

Fig – 4.1 Basic Circuit

4.5 PROCEDURE:

1. Connect the circuit as shown in the circuit diagram of fig. 4.1.

2. Set the value of frequency say 100 Hz in the function generator.
3. Adjust the ground of channel 1 and 2 of Cathode Ray Oscilloscope and then set it into DC mode.
4. Connect CRO across the load in DC mode and observe the waveform. Adjust the DC offset of function generator.
5. Note down the amplitude and frequency.
6. Set the multimeter into AC mode and measure input voltage and voltage across point AB. This value gives RMS value of sinusoidal AC.
7. Calculate the average value.
8. Repeat experiment for different frequency and different peak to peak voltage.
9. Measure the RMS and Average value of DC signal also where instead of function generator you can use DC supply.

4.5 OBSERVATIONS & CALCULATIONS:

Peak value	RMS value	Average value
(V)	(V)	(V)

4.6 PRECAUTIONS:

1. Check for proper connections before switching ON the supply
2. Make sure of proper color coding of resistors
3. The terminal of the resistance should be properly connected

4.7 RESULT:

(B) AVERAGE VALUE, RMS VALUE, FORM FACTOR, PEAK FACTOR OF SINUSOIDAL WAVE, SQUARE WAVE USING DIGITAL SIMULATION

4.8 AIM:

To Determine the average value, RMS value, form factor, peak factor of sinusoidal wave, square wave.

4.9 APPARATUS:

S. No	SOFTWARE USED	DESKTOP QUANTITY
1	MATLAB	01

4.10 CIRCUIT DIAGRAM:

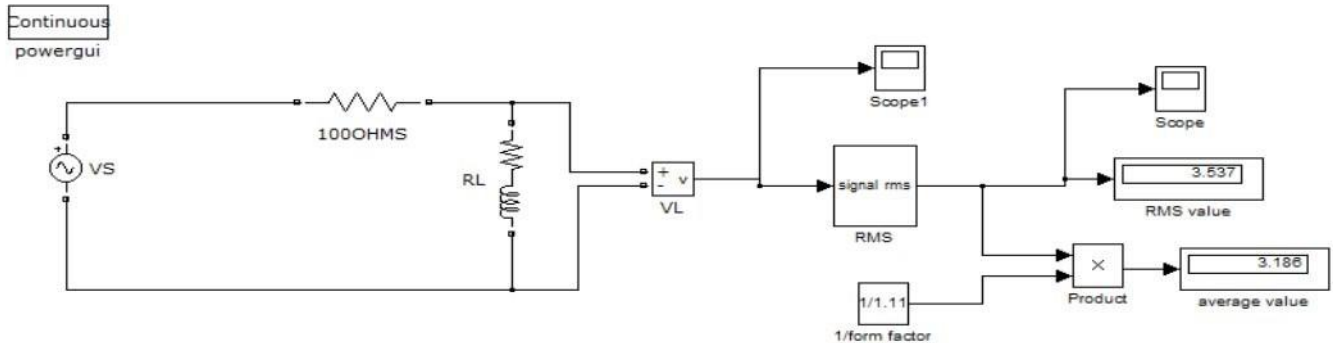

Fig – 4.2 MATLAB Simulink circuit

4.11 PROCEDURE:

1. Make the connections as shown in the circuit diagram by using MATLAB Simulink.
2. Measure the Peak value of the voltage obtained
3. Verify with the practical results obtained with theoretical results

4.12 OBSERVATIONS & CALCULATIONS:

Peak value (V)	RMS value (V)	Averagevalue (V)

4.13 RESULT:

4.14 PRE LAB VIVA QUESTIONS:

1. What is complex wave?
2. Define Instantaneous value.
3. Why RMS value is not calculated for DC quantity?
4. Define RMS Value.
5. What is the expression for form factor and peak factor?

4.15 POST LAB VIVA QUESTIONS:

1. What is RMS value of Sin wave?
2. Why RMS value is specified for alternating Quantity?

-
3. Why average value is calculated for half cycle for an sine wave?
 4. Define form factor and peak factor for an alternating wave.

EXPERIMENT - 5

(A) VERIFICATION OF SUPERPOSITION THEOREM

5.1 AIM:

To Verify principle of Superposition theoretically and practically.

STATEMENT:

In an linear, bilateral network the response in any element is equal to sum of individual responses While all other sources are non-operative.

5.2 APPARATUS:

S.No.	Equipment	Range	Type	Quantity
1.	Resistors	-	-	
2.	Ammeter			
3.	R.P.S			
4.	Bread Board	-	-	
5.	Connecting Wires			required

5.3 CIRCUIT DIAGRAM:

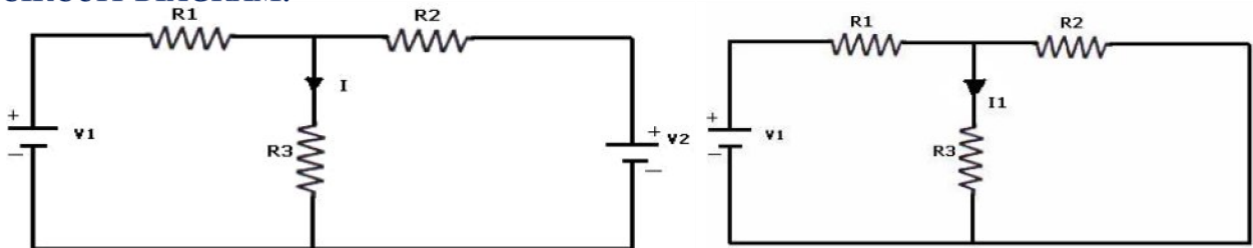

Fig - 5.1 Both Voltage Sources are acting (V_1 & V_2) Fig - 5.2 Voltage Source V_1 is acting alone

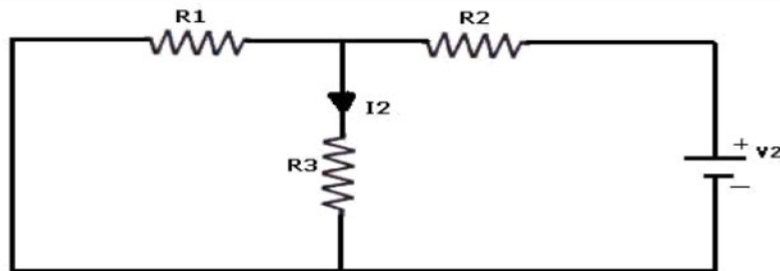

Fig - 5.3 Voltage Source V_2 is acting alone

5.4 PROCEDURE:

1. Connect the circuit as shown in figure (5.1) and note down the current flowing through R_3 and let it be I .
2. Connect the circuit as shown in figure (5.2) and note down the ammeter Reading, and let it be I_1 .
3. Connect the circuit as shown in figure (5.3) and note down the ammeter reading, and let it be I_2 .
4. Verify for $I=I_1+I_2$.

5. Compare the practical and theoretical currents.

5.5 TABULAR COLUMN:

PARAMETERS	WHEN BOTH V_1 & $V_2 \neq 0$ (I)	WHEN $V_1 \neq 0$ & $V_2 = 0$ (I₁)	WHEN $V_1 = 0$ & $V_2 \neq 0$ (I₂)
Current through R ₃ (Theoretical Values)			
Current through R ₃ (Practical Values)			

5.6 PRECAUTIONS:

1. Check for proper connections before switching ON the supply
2. Make sure of proper color coding of resistors
3. The terminal of the resistance should be properly connected

5.7 RESULT

(B) VERIFICATION OF SUPERPOSITION THEOREM USING DIGITAL SIMULATION.

5.8 AIM:

To verify Superposition theorem using digital simulation.

5.9 APPARATUS:

S. No	SOFTWARE USED	DESK TOP QUANTITY
1	MATLAB	01

5.10 CIRCUIT DIAGRAMS:

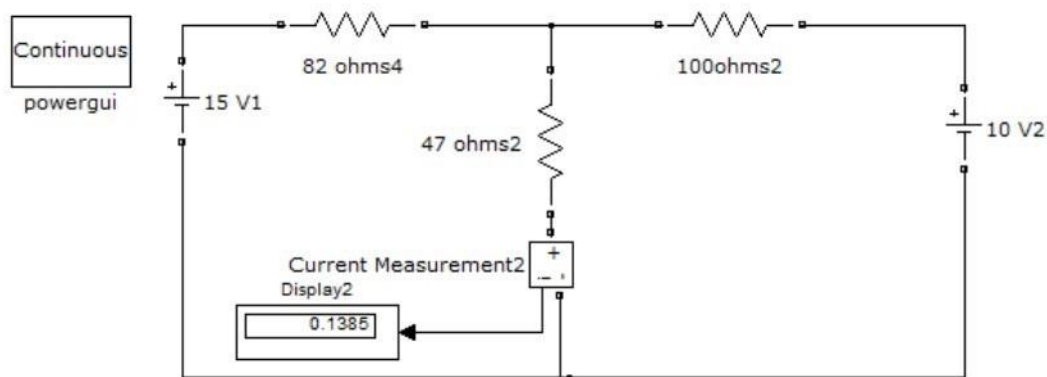

Figure – 5.4 Verification of super position theorem.

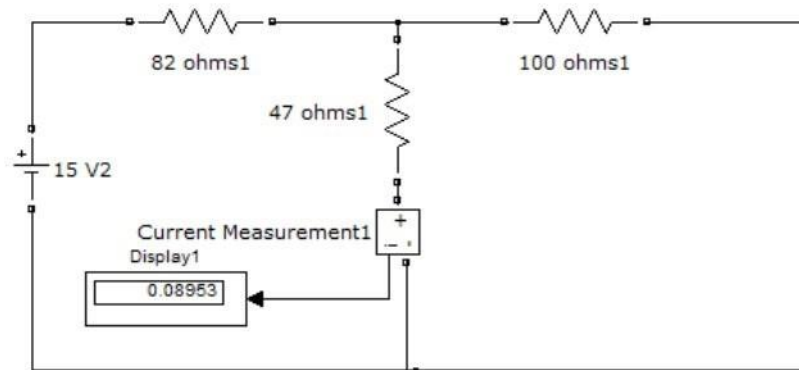

Figure – 5.5. Verification of super position theorem.

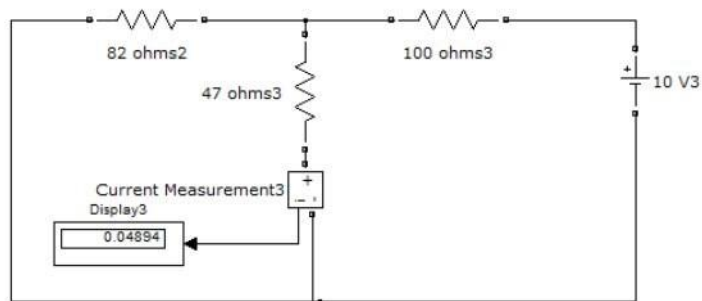

Figure – 5.6. Verification of super position theorem.

5.11 PROCEDURE:

1. Make the connections as shown in the circuit diagram by using MATLAB Simulink.
2. Measure the current in each circuit using current measurement.
3. Verify with the theoretical results obtained with practical results

5.12 RESULT:

5.13 PRE LAB VIVA QUESTIONS:

1. State Superposition theorem.
2. How to find power using Superposition theorem?
3. Write applications of super position theorem.

5.14 POST LAB VIVA QUESTIONS:

1. Is it possible to apply Superposition theorem to nonlinear circuit?
2. Is it possible to apply Superposition theorem to ac as well as dc circuit?

EXPERIMENT – 6

(A) VERIFICATION OF RECIPROCALITY THEOREM

6.1 AIM:

To verify the condition of Reciprocity for an electric network.

6.2 STATEMENT

In any linear, bilateral, single source network the ratio of excitation to response is constant even when their positions are inter - changed.

6.3 APPARATUS:

S. No.	Name of the Equipment	Range	Type	Quantity
1	Ammeter			
2	Voltmeter			
3	R.P.S			
4	Resistors			
5	Bread Board			
6	Connecting Wires			

6.4 CIRCUIT DIAGRAM:

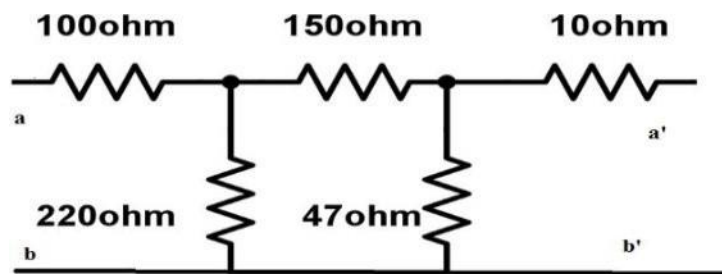

Fig - 6.1 Basic Circuit

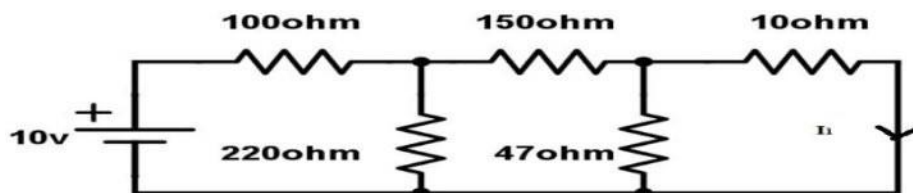

Fig – 6.2 Response due to 10v before interchanging load

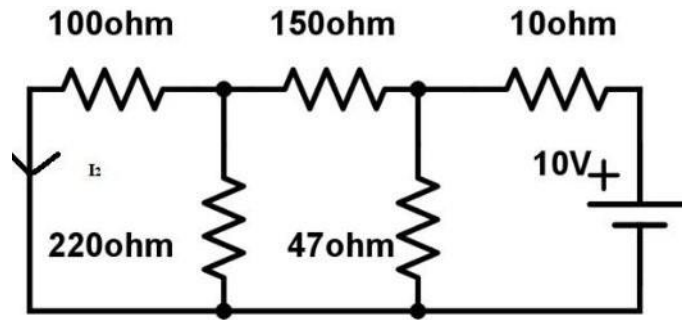

Fig – 6.3 Response due to 10v after interchanging load

6.5 PROCEDURE:

1. Connect the circuit as shown in fig 6.2.
2. Measure the current I1 in the branch.
3. Inter - change voltage source and response as shown in fig6.3 and note down the current I2.
4. Observe that the currents I1 and I2 should be same.
5. Measure the ratio of excitation and response and check whether they are equal in both cases or not.

6.6 TABULAR COLUMN:

Parameters	Theoretical Values	Practical Values

6.7 PRECAUTIONS:

1. Check for proper connections before switching ON the supply
2. Make sure of proper color coding of resistors
3. The terminal of the resistance should be properly connected

6.8 RESULT

(B) VERIFICATION OF RECIPROCITY THEOREM USING DIGITAL SIMULATION.

6.9 AIM:

To verify Reciprocity theorem using digital simulation.

6.10 APPARATUS:

S. No	SOFTWARE USED	DESK TOP QUANTITY
1	MATLAB	01

6.11 CIRCUIT DIAGRAMS:

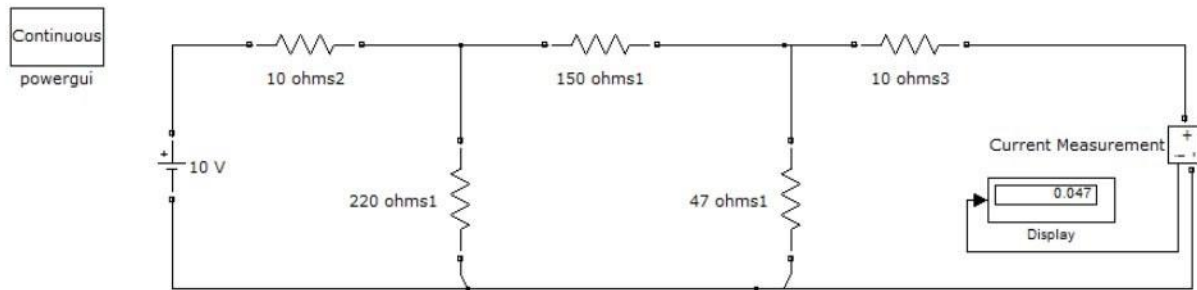

Fig – 6.4 Response due to 10v before interchanging load

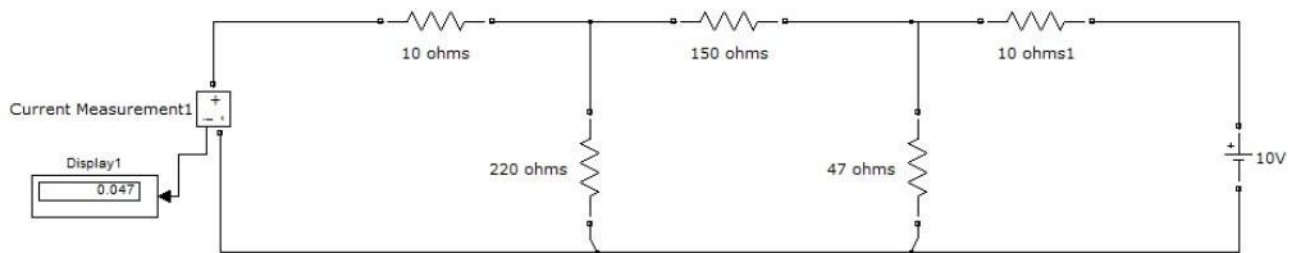

Fig – 6.5 Response due to 10v after interchanging load

6.12 PROCEDURE:

1. Make the connections as shown in the circuit-6.4&6.5 diagram by using MATLAB Simulink.
2. Measure response current in the resistor in 10 ohms circuit-6.4.
3. Measure response current in the resistor in 10 ohms circuit-6.5.
4. Verify the reciprocity theorem.

6.13

PRE LAB VIVA QUESTIONS:

1. State reciprocity theorem.
2. Is it possible to apply both theorems to ac as well as dc circuit?
3. Is Reciprocity applicable for unilateral and bilateral networks?

6.14 LAB ASSIGNMENT:

1. State and prove reciprocity theorem.
2. State applications of reciprocity theorem.

6.15 POST LAB VIVA QUESTIONS:

1. Comment on the applicability of reciprocity theorem on the type of network.
2. Is reciprocity theorem applicable for networks with current source?

EXPERIMENT – 7

(A) VERIFICATION OF MAXIMUM POWER TRANSFER THEOREM

7.1

AIM:

To design the load resistor which absorbs maximum power from source.

7.2

STATEMENT:

The maximum power transfer theorem states that maximum power is delivered from a source to an load resistance when the load resistance is equal to source resistance. ($R_L = R_s$ is the condition required for maximum power transfer).

7.3

CIRCUIT DIAGRAM:

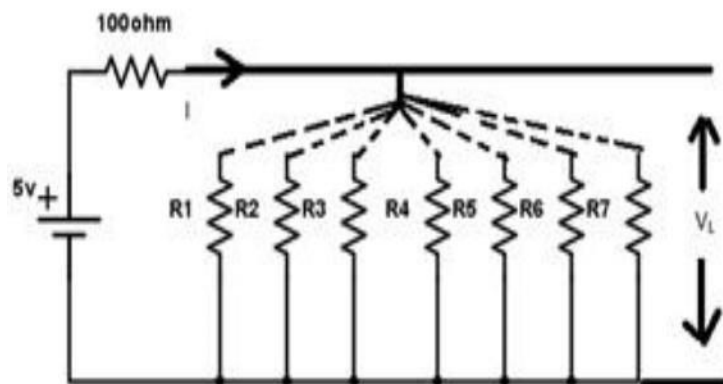

Fig – 7.1 Maximum Power Transfer Circuit

7.4

PROCEDURE:

1. Connect the circuit as shown in fig.7.1
2. Vary the load resistance in steps and note down voltage across the load and current flowing through the circuit.
3. Calculate power delivered to the load by using formula $P=V \cdot I$.
4. Draw the graph between resistance and power (resistance on X- axis and power on Y-axis).
5. Verify the maximum power is delivered to the load when $R_L = R_s$ for DC.

7.5 TABULAR COLUMN:

S. No	RL	V	I	P=VI
1				
2				
3				
4				
5				

7.6 MODEL GRAPH:

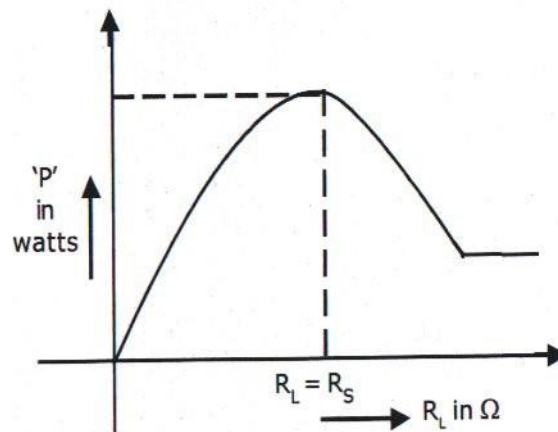

Fig – 7.2 Output Graph of Maximum Power Transfer Theorem

7.7 PRECAUTIONS:

1. Check for proper connections before switching ON the supply
2. Make sure of proper color coding of resistors
3. The terminal of the resistance should be properly connected

7.8 RESULT

(B)VERIFICATION OF MAXIMUM POWER TRANSFER THEOREM

7.9 AIM:

To verify maximum power transfer theorem using digital simulation.

7.10 APPARATUS:

S. No	SOFTWARE USED	DESK TOP QUANTITY
1	MATLAB	01

7.11 CIRCUIT DIAGRAMS:

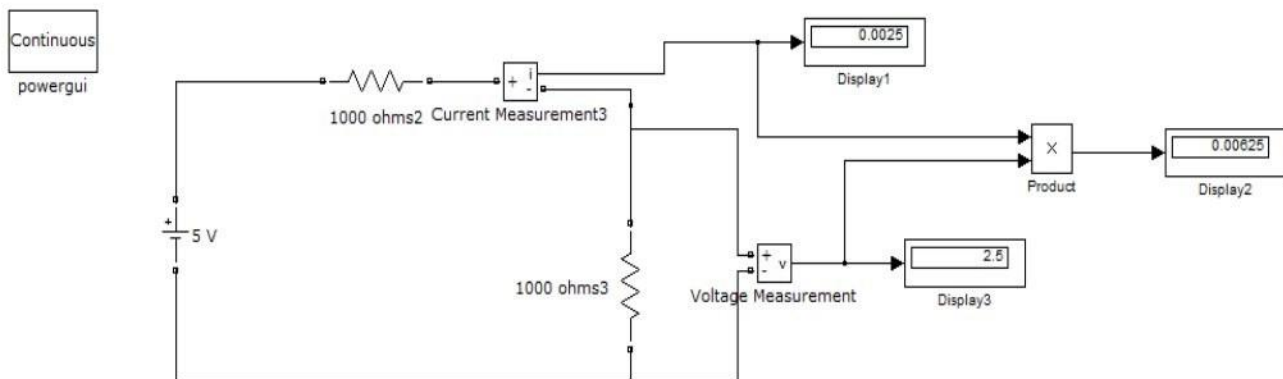

Fig-7.3 Maximum Power Transfer Circuit

7.12 PROCEDURE:

1. Make the connections as shown in the circuit-7.3 diagram by using MATLAB Simulink.
2. Measure the voltage and current through the load resistor using voltage measurement and current measurement
3. Calculate the power .
4. Find the resistance at which maximum power delivered

7.13 RESULT:

7.14 PRELAB VIVAQUESTIONS:

1. State maximum power transfer theorem.
2. Is it possible to apply maximum power transfer theorem to ac as well as dc circuit?
3. How to find power using maximum power transfer theorem?

7.15 LAB ASSIGNMENT:

1. State and prove maximum power transfer theorem for dc circuit.
2. State and prove maximum power transfer theorem for ac circuit.

7.16 POST LAB VIVAQUESTIONS:

1. What are conditions for maximum power transfer theorem?
2. Is it possible to apply maximum power transfer theorem to nonlinear circuit?

EXPERIMENT - 8

(A) VERIFICATION OF THEVENIN'S THEOREM

8.1 AIM:

To Verify Thevenin's theorem.

8.2 APPARATUS:

S.No.	Equipment	Range	Type	Quantity
1	Ammeter			
2	Voltmeter			
3	R.P.S			
4	Bread Board			
5	Resistors			
6	Connecting Wires			As required

8.3 STATEMENT:

Any linear, bilateral network having a number of voltage, current sources and resistances can be replaced by a simple equivalent circuit consisting of a single voltage source in series with a resistance, where the value of the voltage source is equal to the open circuit voltage and the resistance is the equivalent resistance measured between the open circuit terminals with all energy sources replaced by their ideal internal resistances

8.4 CIRCUIT DIAGRAM:

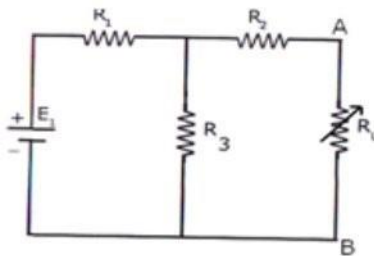

Fig-8.1 Measurement of V_{TH} or V_{OC}

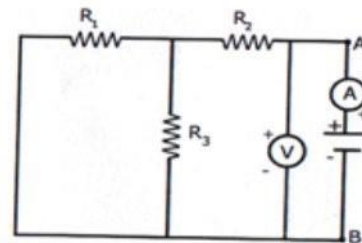

Fig – 8.2 Measurement of R_{TH}

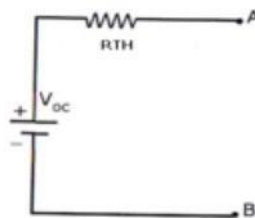

Fig – 8.3 Measurement of I_L ($I_L = V_{TH} \text{ or } V_{OC} / R_{TH} + R_L$)

8.5

PROCEDURE:

1. Connect the circuit diagram as shown in fig.8.1
2. Measure current in R_L .
3. Connect the circuit as shown in fig8.2.
4. Measure open circuit voltage V_{oc} by open circuiting terminals i.e, V_{TH}
5. Draw the Thevenin's equivalent circuit as shown in fig8.3
6. Measurement current in R_L

8.6.1 TABULAR COLUMN:

Parameters	Theoretical Values	Practical Values
V_{oc}		
R_{TH}		
I_L		

8.7 PRECAUTIONS:

1. Check for proper connections before switching ON the supply
2. Make sure of proper color coding of resistors
3. The terminal of the resistance should be properly connected.

8.8

RESULT:

(B)VERIFICATION OF THEVENIN'S THEOREM USING DIGITAL SIMULATION.

8.9

AIM:

To verify Thevenin's theorem using digital simulation.

8.10 APPARATUS:

S. No	SOFTWARE USED	DESK TOP QUANTITY
1	MATLAB	01

8.11 CIRCUIT DIAGRAMS:

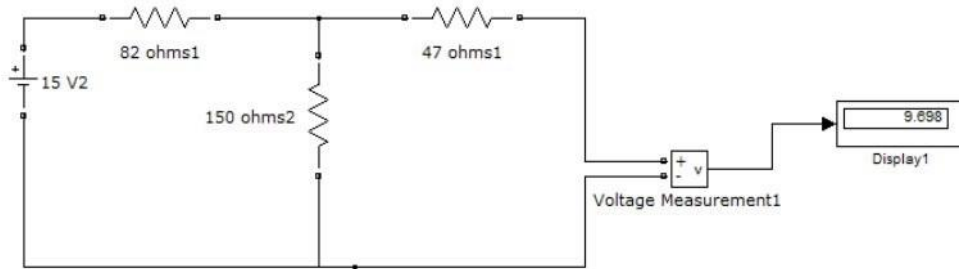

Fig – 8.4 Measurement of V_{TH} or V_{OC}

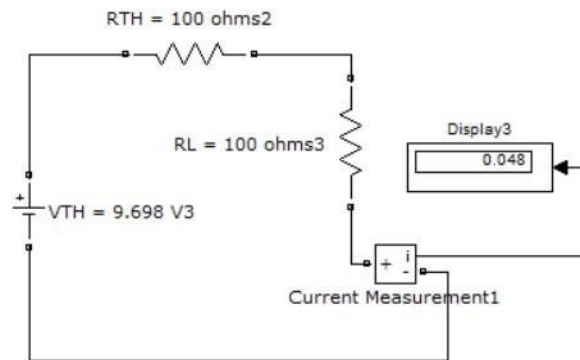

Fig – 8.5 Measurement of I_L ($I_L = V_{TH} / R_{TH} + R_L$)

8.12 PROCEDURE:

1. Make the connections as shown in the circuit-8.4 diagram by using MATLAB Simulink.
2. Measure the open circuit voltage across the load terminals using voltage measurement.
3. Connect circuit fig 8.5 Thevenin's equivalent circuit in MATLAB and find the load current.

8.12 RESULT:

8.13 PRE LAB VIVA QUESTIONS:

1. What is load resistance?
2. How will you calculate Thevenin's resistance R_{TH} ?
3. How will you calculate Thevenin's voltage V_{TH} ?
4. How will you calculate load current I_L ?

8.14

LAB ASSIGNMENT:

1. Solve the theoretical value of Thevenin's theorem for different circuits.
2. Solve the theoretical value of Thevenin's resistance for different circuits.

8.15 POST LAB VIVA QUESTIONS:

1. Write the applications of Thevenin's theorem.
2. Write the limitations of Thevenin's theorem.

EXPERIMENT - 9

(A) VERIFICATION OF NORTON'S THEOREM

9.1

AIM:

To Verify Norton's theorem.

9.2

STATEMENT

Any linear, bilateral network with current sources, voltage sources and resistances can be replaced by an equivalent circuit consisting of a current source in parallel with a resistance. The value of the current source is the current flowing through the short circuit terminals of the network and the resistance is the equivalent resistance measured between the open circuit terminals of the network with all the energy sources replaced by their internal resistances.

9.3

CIRCUIT DIAGRAM:

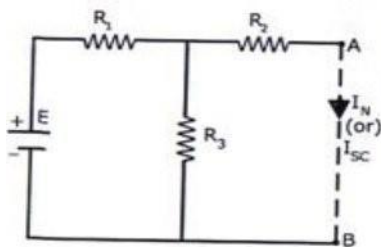

Fig – 9.1 Norton's

Current Circuit

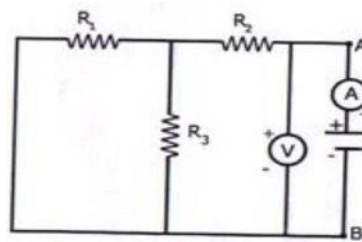

Fig – 9.2 Norton's

Equivalent Resistance circuit

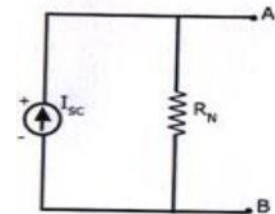

Fig – 9.3 Norton's

Equivalent Circuit

9.4

PROCEDURE:

1. Connect the circuit diagram as shown in fig 9.1.
2. Measure the current I_{sc} (or) I_N through AB by short-circuiting the resistance between A and B.
3. Connect the circuit diagram as shown in fig 9.2.
4. The resistance between A and B are obtained by using. Voltmeter, ammeter method and the ratio of V and I gives R_N .
5. Draw Norton's equivalent circuit by connecting I_N & R_N in parallel as shown in fig 9.3 and find load current.

9.5 TABULAR COLUMN:

Parameters	Theoretical Values	Practical Values
Isc/ IN		
RN		
IL		

9.6 RESULT:

(B) VERIFICATION OF NORTON'S THEOREM USING DIGITAL SIMULATION

9.7 AIM:

To verify Norton's theorem using digital simulation.

9.8 APPARATUS:

S. No	SOFTWARE USED	DESK TOP QUANTITY
1	MATLAB	01

9.9 CIRCUIT DIAGRAMS:

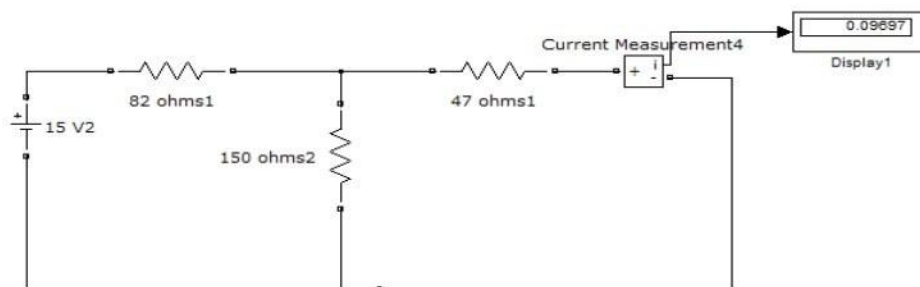

Fig-9.4 Norton's current in MATLAB

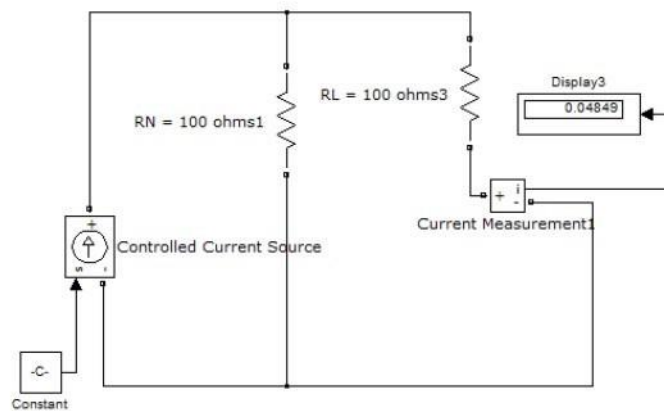

Fig-9.5 Load current in MATLAB

9.9

PROCEDURE:

1. Make the connections as shown in the circuit-9.4 diagram by using MATLAB Simulink.
2. Measure the short circuit current through the load terminals using current measurement.
3. Connect circuit fig 9.5 Norton's equivalent circuit in MATLAB and find the load current.

9.10

PRECAUTIONS:

1. Check for proper connections before switching ON the supply
2. Make sure of proper color coding of resistors
3. The terminal of the resistance should be properly connected

9.11

RESULT:

9.12

PRE LAB VIVA QUESTIONS:

1. State Norton's theorem.
2. Define R_N .
3. Define I_N .

9.13

LAB ASSIGNMENT:

1. State and prove Norton's theorem.
2. Derive the value of R_N .
3. Find Norton's equivalent resistance from the circuit having dependent source?

9.14 POST LAB VIVA QUESTIONS:

1. Convert Thevenin's equivalent into Norton's equivalent.
2. Is it possible to apply Norton's theorem ac as well as dccircuit?
3. What are the applications of Norton's theorem?

EXPERIMENT – 10

(A) VERIFICATION OF COMPENSATION THEOREM

10.1 AIM:

To verify the compensation theorem and to determine the change in current.

10.2 APPARATUS:

S. No.	Name of the Equipment	Range	Type	Quantity
1	Ammeter			
2	Voltmeter			
3	R.P.S			
4	Resistors			
5	Bread Board			
6	Connecting Wires			

10.3 STATEMENT

Compensation theorem states that any element in electrical network can be replaced by its equivalent voltage source, whose value is equal to product of current flowing through it and its value. (Compensation theorem

got the importance of determining the change in current flowing through element or circuit because of change in the resistance value).

10.4 CIRCUIT DIAGRAM:

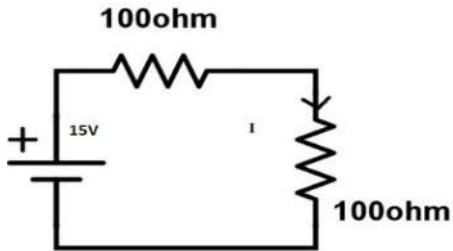

Fig – 10.1 Basic Circuit

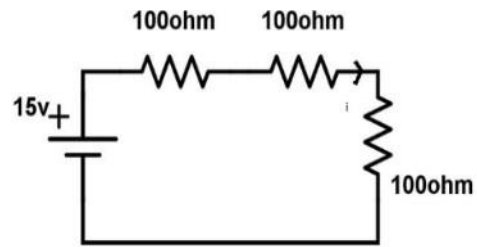

Fig – 10.2 After change in resistance circuit

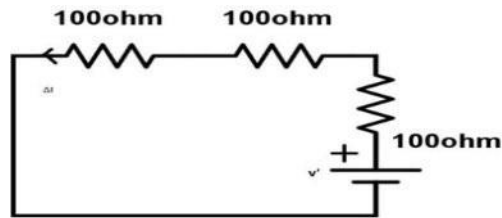

Fig -10.3 Compensation Theorem Circuit

10.5

PROCEDURE:

1. Connect the circuit as shown in fig10.1.
2. Measure the current I.
3. Connect the circuit as shown in fig10.2. by increasing the circuit resistance(ΔR), Measure the current I1.
4. The change in current in the circuit can be found by connecting a voltage source equal to $I1\Delta R$ as shown in fig10.3.
5. Measure the current I" i.e., the change in current.
6. Observe that $I'' = I - I1$.

10.5 TABULAR COLUMN:

S.No.	Parameters	Theoretical value	Practical value
1			
2			
3			

10.6 RESULT:

(B) VERIFICATION OF COMPENSATION THEOREM USING DIGITAL SIMULATION

10.7 AIM:

To verify compensation theorem using digital simulation.

10.8 APPARATUS:

S. No	SOFTWARE USED	DESK TOP QUANTITY
1	MATLAB	01

10.9

CIRCUIT DIAGRAMS:

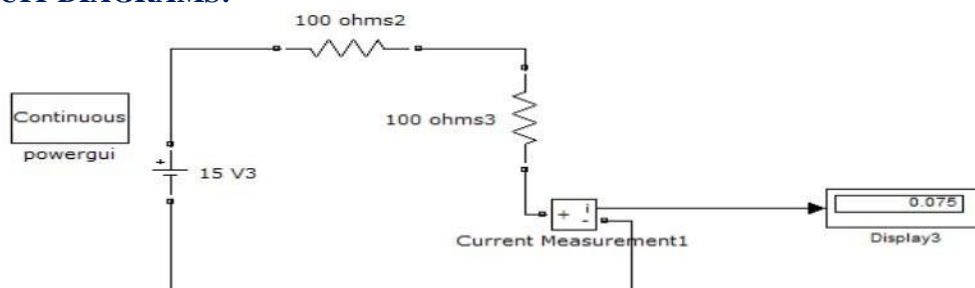

Fig -10.4 Basic circuit in MATLAB.

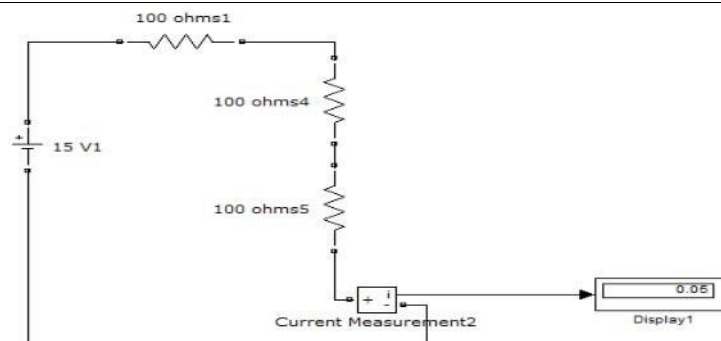

Fig -10.5 After compensation of resistance circuit in MATLAB

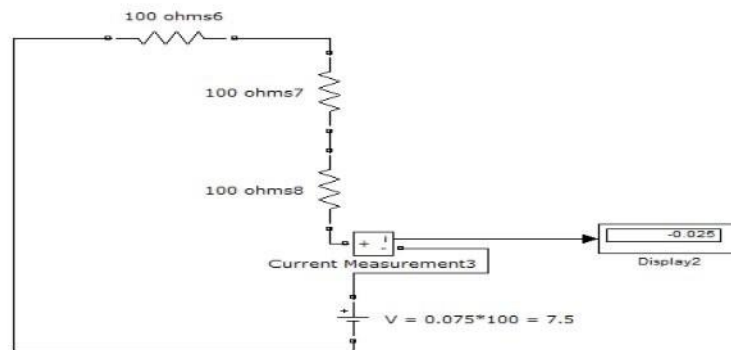

Fig -10.6 Compensation Theorem Circuit in MATLAB

10.10 PROCEDURE:

1. Make the connections as shown in the circuit diagrams by using MATLAB Simulink.
2. Using fig.10.4 find the current flowing through original circuit.
3. Using fig 10.5 find current flowing through the change in resistance.
4. Using fig10.6 find the changed current.

10.11 PRECAUTIONS:

1. Check for proper connections before switching ON the supply
2. Make sure of proper color coding of resistors
3. The terminal of the resistance should be properly connected

10.12 RESULT:

10.13

PRE LAB VIVA QUESTIONS:

1. What is Compensation theorem?
2. Is it possible to apply compensation theorem to ac as well as dc circuit?
3. Is Compensation theorem applicable for unilateral and bilateral networks?

10.14

LAB ASSIGNMENT:

1. State and prove Compensation theorem.
2. Give the importance of Compensation theorem.

10.15 POST LAB VIVA QUESTIONS:

1. Which condition is required to apply the Compensation theorem for the circuit?
2. Comment on the applicability of Compensation theorem on the type of network.
3. Give the importance of compensation theorem.

EXPERIMENT – 11

A) VERIFICATION OF MILLIMAN'S THEOREM

11.1 AIM:

To verify the Milliman's Theorem.

11.2 STATEMENT:

This theorem states that in any network, if the voltage sources V_1, V_2, \dots, V_n in series with their internal resistances R_1, R_2, \dots, R_n respectively are in parallel, then these sources may be replaced by a single voltage source V' in series-with R_1 .

$$V' = \frac{V_1 G_1 + V_2 G_2 + \dots + V_n G_n}{G_1 + G_2 + \dots + G_n}$$

$$R_1 = \frac{1}{G_1 + G_2 + \dots + G_n}$$

11.3 APPARATUS:

S. No.	Name of the Equipment	Range	Type	Quantity
1	Ammeter			
2	Voltmeter			
3	R.P.S			
4	Resistors			
5	Bread Board			
6	Connecting Wires			

11.4 CIRCUIT DIAGRAM:

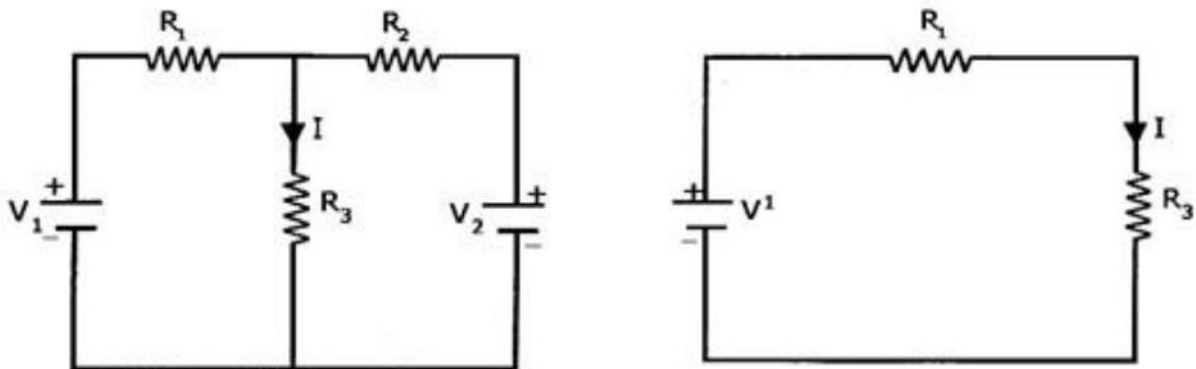

Fig – 11.1 Basic Circuit

Fig – 11.2 Millman's Circuit

11.5 PROCEDURE:

1. Connect the circuit as shown in fig.11.1
2. Measure the current through the resistor R3.
3. Connect the circuit as shown in fig.11.2 and measure the current through R3.
4. Observe that the two currents are same.

11.6 TABULAR COLUMN:

S.No.	Parameters	Theoretical value	Practical value
1			
2			

11.7 RESULT:

(B)VERIFICATION OF MILLIMAN’S THEOREM USING DIGITAL SIMULATION

11.8 AIM:

To verify Milliman’s theorem using digital simulation.

11.9 APPARATUS:

S. No	SOFTWARE USED	DESK TOP QUANTITY
1	MATLAB	01

11.10 CIRCUIT DIAGRAMS:

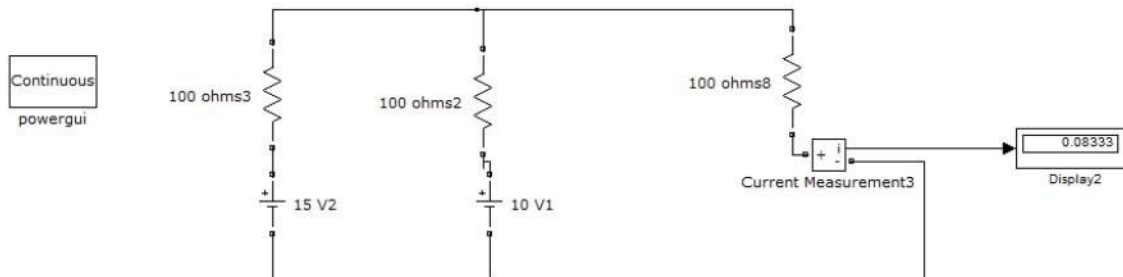

Fig – 11.3 Simulation Basic Circuit

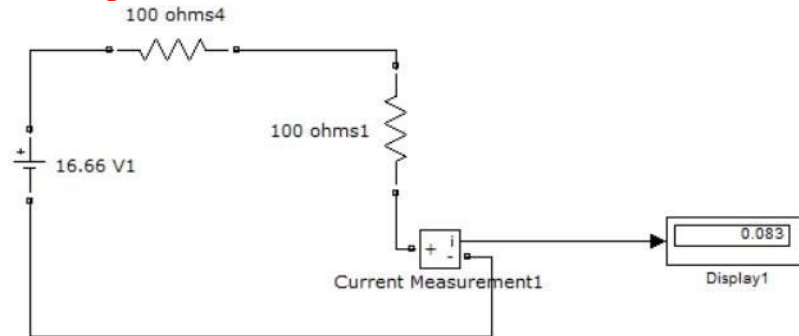

Fig – 11.4 Simulation Millman's Circuit

11.11 PROCEDURE:

1. Connect the circuit as shown in fig 11.3 using MAT LAB Simulink.
2. Measure the current through the resistor R3.
3. Connect the circuit as shown in fig.11.4 and measure the current through R3.
4. Observe that the two currents are same.

11.12 RESULT:

11.13 PRE LAB VIVA QUESTIONS:.

1. State Millman's theorem.
2. Is it possible to apply both theorems to ac as well as dccircuit?
3. Is Millman's is applicable for unilateral and bilateral networks?

11.14 LAB ASSIGNMENT:

1. State and prove Millman's theorem.
2. State application of Millman's theorem.

11.15 POST LAB VIVA QUESTIONS:

1. Which condition is required to apply the Millman's theorem for the circuit?

-
2. Comment on the applicability of Milliman's theorem on the type of network.

EXPERIMENT – 12

(A) VERIFICATION OF SERIES RESONANCE

12.1 AIM:

To design the resonant frequency, quality factor and band width of a series resonant circuit.

12.2 APPARATUS:

S. No.	Name of the Equipment	Range	Type	Quantity
1	Signal generator			
2	Required resistors			
3	Required Inductors			
4	Required capacitors			
5	CRO probes			
6	Connecting wires			

12.3

CIRCUIT DIAGRAM:

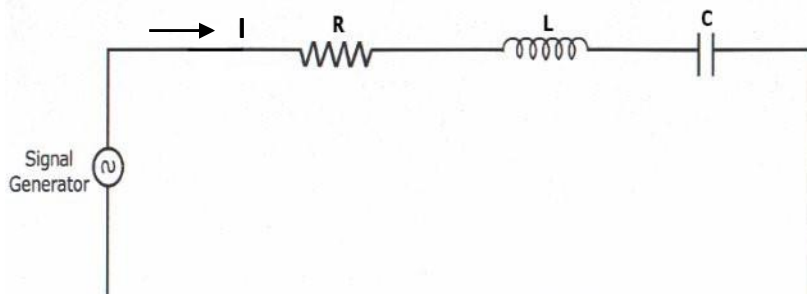

Fig – 12.1 Series Resonance

12.4 PROCEDURE:

1. Connect the circuit as shown in fig.12.1 for series resonant circuit
2. Set the voltage of the signal from function generator to 10V.
3. Vary the frequency of the signal in steps and note down the magnitude of response on CRO respectively.(response wave form is observed across element R)
4. Form the observation table between the frequency and magnitude of response in CRO for series resonance circuit.
5. Draw a graph between frequency and magnitude of response on the semi-log sheet and determine the resonant frequency, quality factor and bandwidth of series RLC circuit\.

12.5

THEORETICAL CALCULATIONS:

Series Resonance

Resonant Frequency $(f_r) = 1/(2\pi\sqrt{LC})$ Lower cut

off frequency $(f_1) = f_r - R/4\pi L$

Upper cut off frequency $(f_2) = f_r + R/4\pi L$ Quality

factor $Q_r = \omega_r L/R = 1/\omega_r RC$

Band Width $f_2 - f_1 = R/2\pi L$

12.6 TABULAR COLUMN:

S.No.	Frequency (Hz)	Magnitude of response
1		
2		
3		
4		
5		
6		
7		

8		
9		
10		

12.7

MODEL GRAPH:

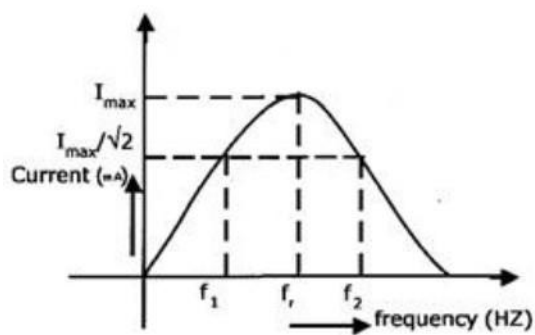

Fig – 12.2 Series Resonance

12.8 RESULT:

(B) DESIGN AND SIMULATION OF SERIES RESONANCE CIRCUIT.

12.9 AIM:

To plot the magnitude curve for various frequencies for the given RLC series circuit.

12.10 SOFTWARE REQUIRED:

S. No	SOFTWARE USED	DESK TOP QUANTITY
1	MATLAB	01

12.11 THEORY:

A circuit is said to be in resonance when applied voltage V and current I are in phase with each other. Thus at resonance condition, the equivalent complex impedance of the circuit consists of only resistance (R) and hence current is maximum. Since V and I are in phase, the power factor is unity.

The complex impedance

$$Z = R + j(XL - XC)$$

Where $XL = \omega L$

$$XC = 1/\omega C$$

At resonance, $XL = XC$ and hence $Z = R$

Bandwidth of a Resonance Circuit:

Bandwidth of a circuit is given by the band of frequencies which lies between two points on either side of resonance frequency, where current falls through 1/1.414 of the maximum value of resonance.

Narrow is the bandwidth, higher the selectivity of the circuit. As shown in the model graph, the bandwidth AB is given by $f_2 - f_1$. f_1 is the lower cut off frequency and f_2 is the upper cut off frequency

12.12 CIRCUIT DIAGRAM:

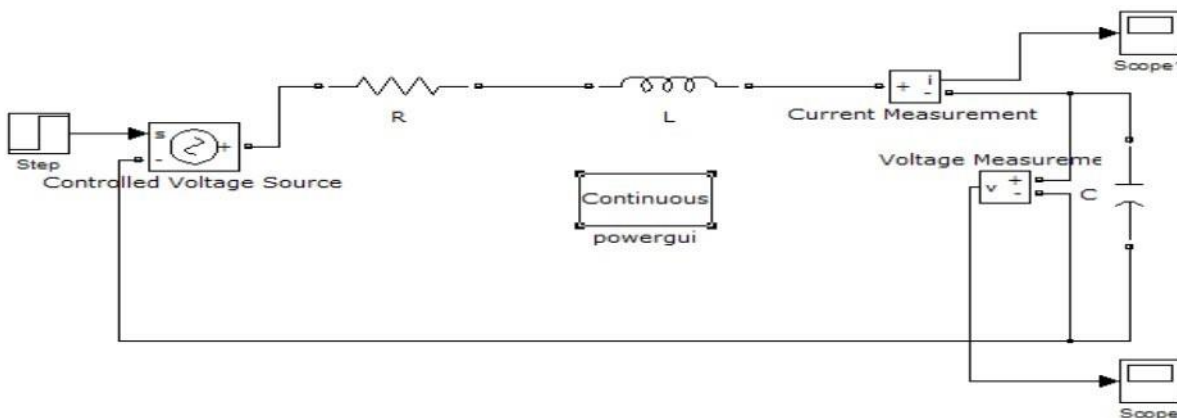

Fig – 12.3 Series Resonance simulation diagram

12.13 PROCEDURE:

1. Open a new MATLAB/SIMULINK model
2. Connect the circuit as shown in the figure12.3
3. Debug and run the circuit
4. By double clicking the powergui plot the value of current for the different values of frequencies

12.14 MODEL GRAPH FOR SERIES RESONANCE

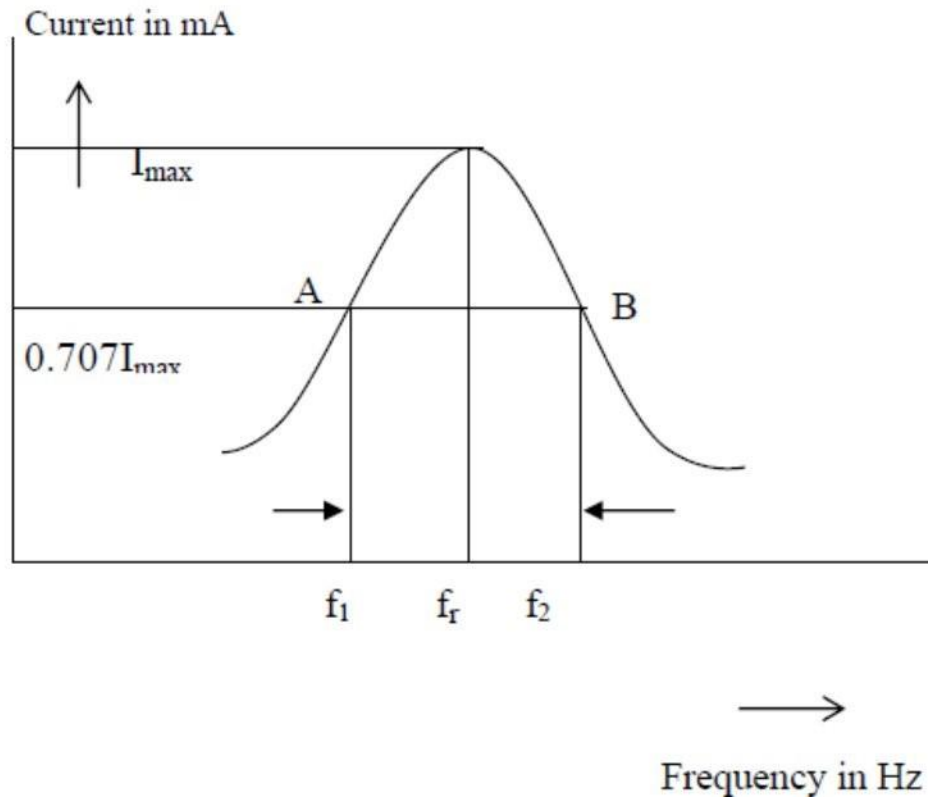

Fig – 12.4 Series Resonance Model graph

12.14 %PROGRAM TO FIND THE SERIES RESONANCE

```
clc;
clear all;
close all;
r=input('enter the resistance value----->');
l=input('enter the inductance value----->');
c=input('enter the capacitance value----->');
v=input('enter the input voltage----->');
f=5:2:300;
xl=2*pi*f*l;
xc=(1./(2*pi*f*c));
x=xl-xc;
```

```
z=sqrt((r^2)+(x.^2));  
i=v./z;  
%plotting the graph  
subplot(2,2,1);  
plot(f,x1); grid;  
xlabel('frequency');  
ylabel('X1');  
subplot(2,2,2);  
plot(f,xc); grid;  
xlabel('frequency');  
ylabel('Xc');  
subplot(2,2,3);  
plot(f,z); grid;  
xlabel('frequency');  
ylabel('Z');  
subplot(2,2,4);  
plot(f,i); grid;  
xlabel('frequency');  
ylabel('I');
```

12.15 PROGRAM RESULT:

enter the resistance value---->100 enter
the inductance value----->10e-3 enter the
capacitance value----->0.1*10^-6 enter
the input voltage----->10

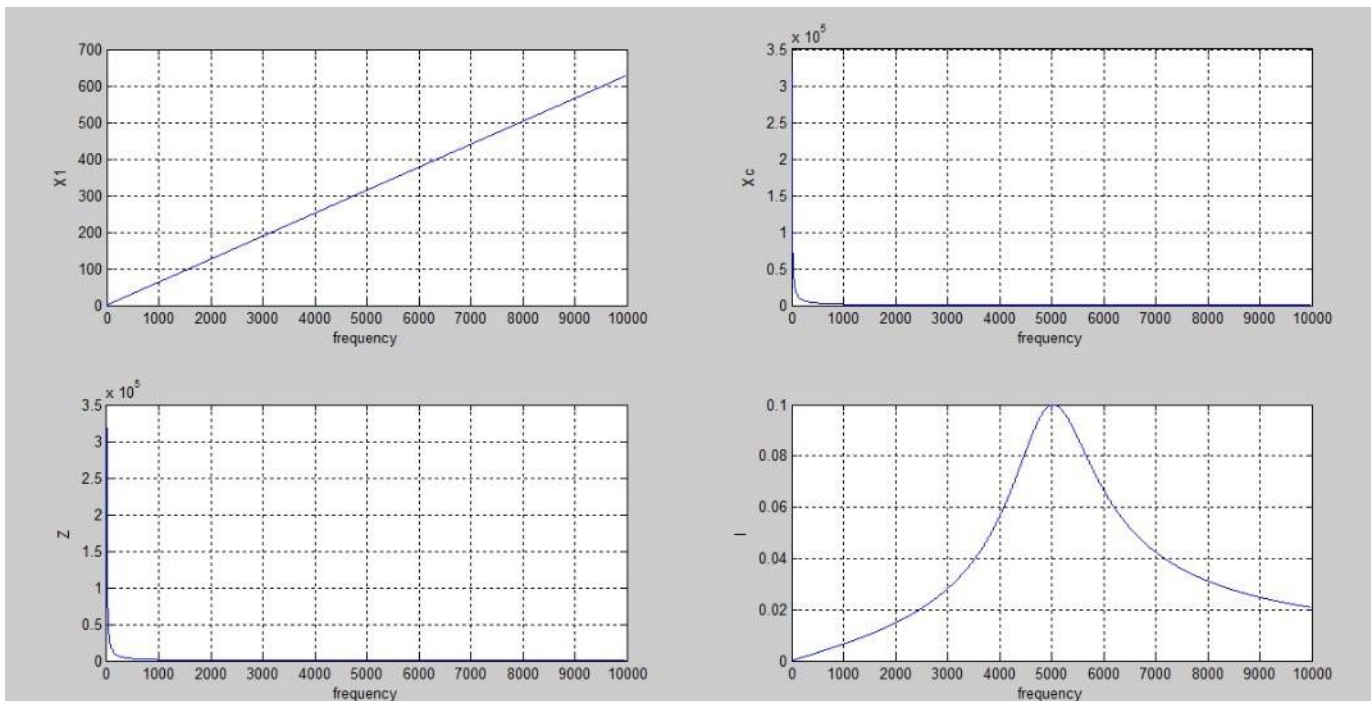

12.16 PRE LAB VIVA QUESTIONS:

1. Define resonance.
2. Give condition for series resonance.
3. Define band width.
4. Define quality factor.
5. What is the importance of quality factor?

12.17 LAB ASSIGNMENT:

1. Define quality factor and give expression for it.
2. Give the application of series resonance circuit.

12.18 POST LAB VIVA QUESTIONS:

1. Define series resonance.
2. Define magnification.
3. What is the power factor under resonant condition?

EXPERIMENT – 13

(A) VERIFICATION OF PARALLEL RESONANCE

13.1

AIM:

To design the resonant frequency, quality factor and band width of a parallel resonant circuit.

13.2

APPARATUS:

S. No.	Name of the Equipment	Range	Type	Quantity
1	Signal generator			
2	Required resistors			
3	Required Inductors			
4	Required capacitors			
5	CRO probes			
6	Connecting wires			

13.3

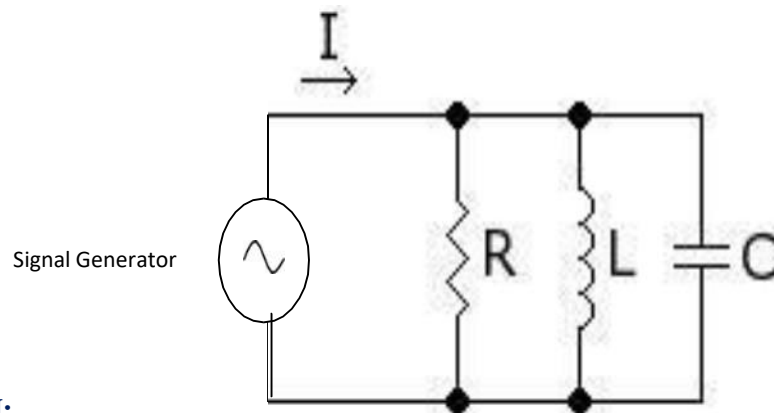

CIRCUIT DIAGRAM:

Fig - 13.1 Parallel Resonance

13.4 PROCEDURE:

1. Connect the circuit as shown in fig.2 for parallel resonant circuit.
2. Set the voltage of the signal from function generator to 10V.
3. Vary the frequency of the signal in steps and note down the magnitude of response on CRO respectively.(response wave form is observed across element R)
4. Form the observation table between the frequency and magnitude of response in CRO firstly for parallel resonance circuit.
5. Draw a graph between frequency and magnitude of response on the semi-log sheet and determine the resonant frequency, quality factor and bandwidth of parallel RLC circuit.

13.5 THEORETICAL CALCULATIONS:

Parallel Resonance

$$\text{Resonant Frequency } (f_r) = \frac{1}{2\pi\sqrt{LC}}$$

$$\text{Lower cut off frequency}(f_1) = f_r - \frac{1}{4\pi RC} \text{ Upper cut}$$

$$\text{off frequency } (f_2) = f_r + \frac{1}{4\pi RC} \text{ Quality}$$

$$\text{factor } Q_r = \omega_r CR = f_r/B.W$$

$$\text{Band Width } f_2 - f_1 = \frac{1}{2\pi RC}$$

13.6 TABULAR COLUMN:

S.No.	Frequency (Hz)	Magnitude of response
1		
2		
3		
4		
5		
6		
7		
8		
9		

10		
----	--	--

13.7

MODEL GRAPH:

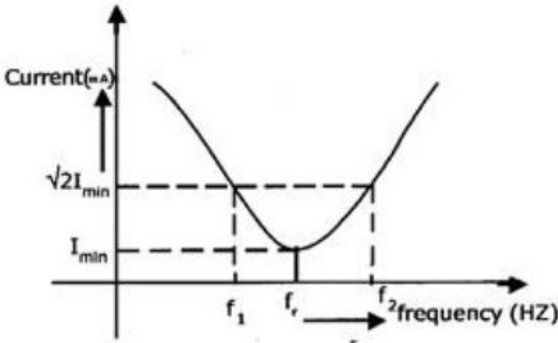

Fig – 13.2. Parallel Resonance

13.8 RESULT

(B) DESIGN AND SIMULATION OF PARALLEL RESONANCE CIRCUIT.

13.9

AIM:

To plot the magnitude of current for various frequencies for the given RLC parallel circuit.

13.10 SOFTWARE REQUIRED:

S. No	SOFTWARE USED	DESK TOP QUANTITY
1	MATLAB	01

13.11

THEORY:

A circuit is said to be in resonance when applied voltage V and current I are in phase with each other. Thus at resonance condition, the equivalent complex impedance of the circuit consists of only resistance (R) and hence current is maximum. Since V and I are in phase, the power factor is unity. The complex impedance

$$Z = R + j(XL - XC)$$

$$\text{Where } XL = \omega L$$

$$XC = 1/\omega C$$

At resonance, $XL = XC$ and hence $Z = R$

Bandwidth of a Resonance Circuit:

Bandwidth of a circuit is given by the band of frequencies which lies between two points on either side of resonance frequency, where current falls through $1/1.414$ of the maximum value of resonance. Narrow is the bandwidth, higher the selectivity of the circuit. As shown in the model graph, the bandwidth AB is given by $f_2 - f_1$. f_1 is the lower cut off frequency and f_2 is the upper cut off frequency.

13.12 PROCEDURE:

1. Open a new MATLAB/SIMULINK model.
2. Connect the circuit as shown in the figure 13.3.
3. Debug and run the circuit.
4. By double clicking the powergui plot the value of current for the different values of frequencies.

13.13 SIMULATION DIAGRAM FOR PARALLEL RESONANCE:

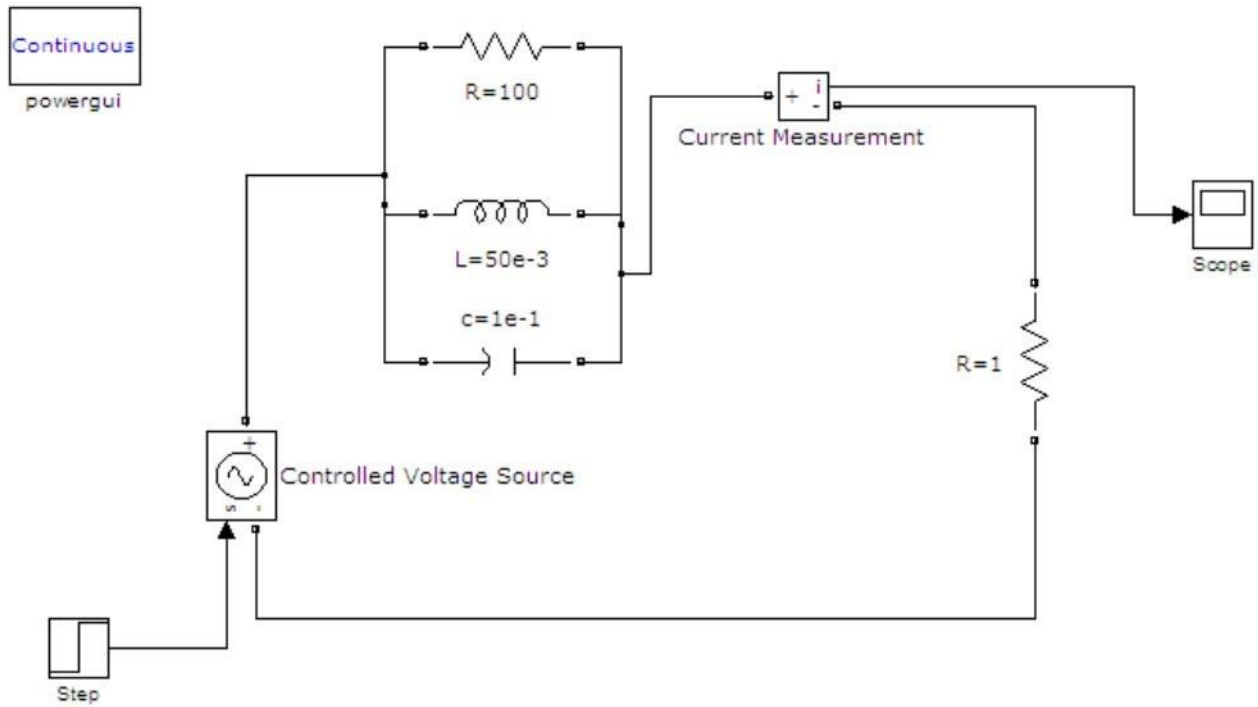
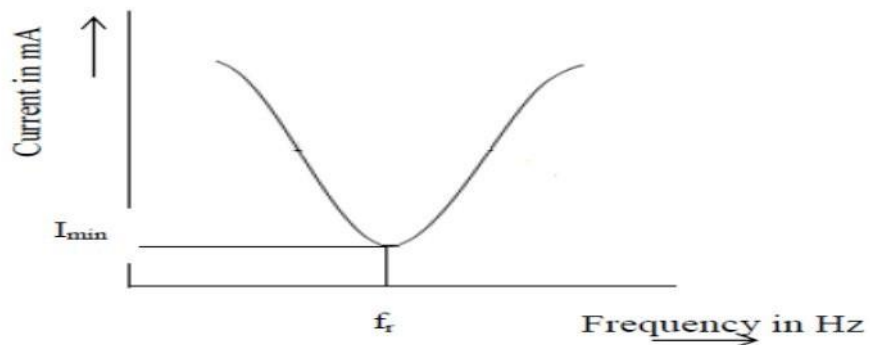

Fig - 13.3 Parallel Resonance

13.14 MODEL GRAPH FOR PARALLEL RESONANCE



To obtain the graphs of frequency vs. BL , frequency vs. BC , frequency vs. admittance and frequency vs. current vary frequency in steps for the given circuit and find the resonant frequency and check by theoretical calculations.

R = 1000W, C = 400 m F, L = 1 H, V = 50V vary frequency in steps of 1 Hz using Matlab.

13.15

%PROGRAM TO FIND THE PARALLEL RESONANCE

```
clc; clear
all; close
all;
r=input('enter the resistance value----->');
l=input('enter the inductance value----->');
c=input('enter the capacitance value-----
>'); v=input('enter the input voltage-----
>'); f=0:2:50; x1=2*pi*f*l;
xc=(1./(2*pi*f*c)); b1=1./x1; bc=1./xc;
b=b1-bc; g=1/r;
y=sqrt((g^2)+(b.^2)); i=v*y;
%plotting the graph
subplot(2,2,1);
plot(f,b1); grid;
xlabel('frequency');
ylabel('B1');
subplot(2,2,2);
plot(f,bc); grid;
xlabel('frequency');
ylabel('Bc');
subplot(2,2,3);
plot(f,y); grid;
xlabel('frequency');
ylabel('Y');
subplot(2,2,4);
plot(f,i); grid;
xlabel('frequency');
```

ylabel(T);

13.16

PRE LAB VIVA QUESTIONS:

1. Define parallel resonance.
2. Give condition for parallel resonance.
3. Define band width.
4. Define quality factor.
5. What is importance of qualityfactor?

13.17

LAB ASSIGNMENT:

1. Define quality factor and give expression for it.
2. Give the application of parallel resonance circuit.

13.18 POST LAB VIVA QUESTIONS:

1. What is the difference between series and parallel resonance?
2. What do you observe from the parallel resonance graphs?

EXPERIMENT – 14

DETERMINATION OF SELF, MUTUAL INDUCTANCE AND COEFFICIENT OF COUPLING

14.1 AIM:

To determine self, mutual inductance and coefficient of coupling of a mutually coupled circuit.

14.2 APPARATUS:

S. No.	Name of the Equipment	Range	Type	Quantity
1	Ammeter			
2	Voltmeter			
3	1-phase Transformer			
4	1-phase Variac			
5	1-ph A.C. Supply			
6	Connecting Wires			

14.3 CIRCUIT DIAGRAM

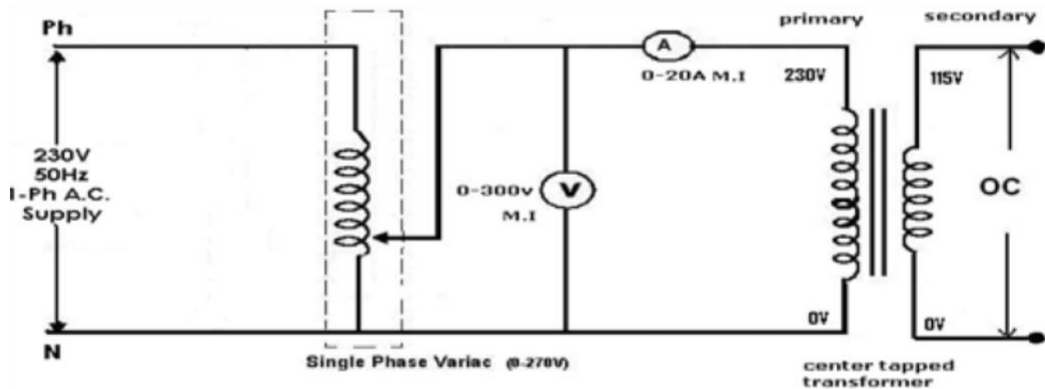

Fig – 14.1 Circuit Diagram of self Inductance of Coil 1

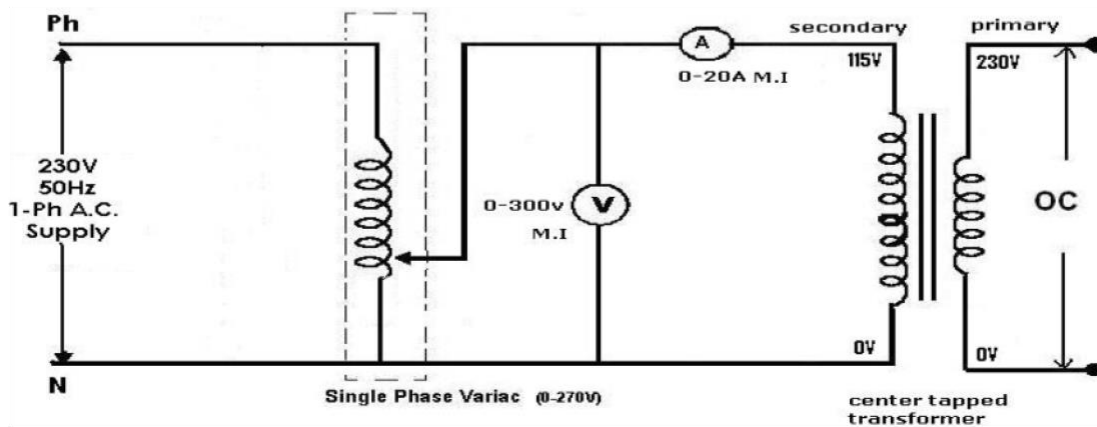

Fig – 14.2 Circuit Diagram of self Inductance of Coil 2

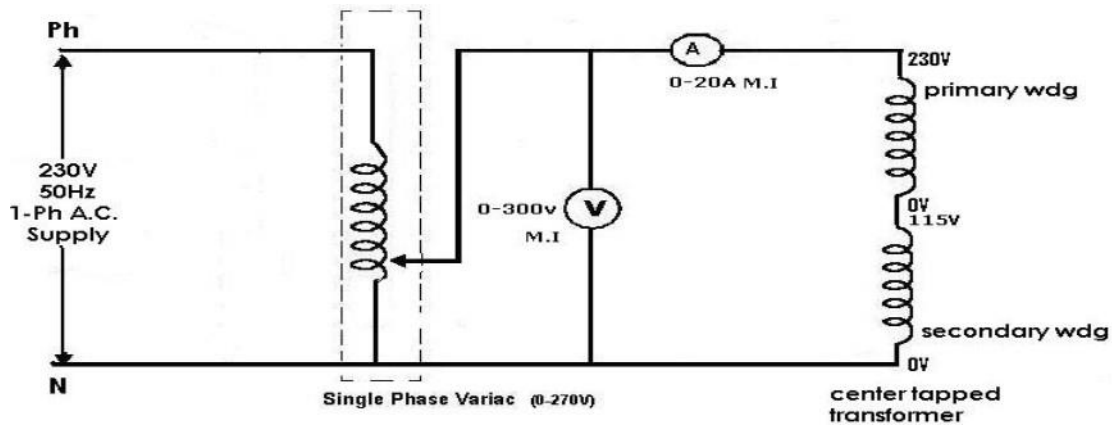

Fig – 14.3 Circuit Diagram of Equivalent Inductance

14.4 PROCEDURE:

1. Connect the circuit as shown in fig.14.1 and measure the self inductance of coil 1 i.e. L_1 by noting the voltmeter and ammeter readings.
2. Connect the circuit as shown in fig.14.2 and measure the self inductance of coil 2 i.e. L_2 by noting the voltmeter and ammeter readings.
3. Connect the circuit as shown fig.14.3 and note down voltmeter (V) and ammeter (A) readings and determine equivalent inductance L_{eq} .
4. Calculate coefficient of coupling.

14.5 THEORETICAL CALCULATIONS:

(Neglect winding resistance)

$$L_{eq} = L_1 + L_2 \pm 2M$$

$$\text{Mutual Inductance } M = [(L_{eq} - (L_1 + L_2)) / 2]$$

$$\text{Coefficient of Coupling } K = M / \sqrt{L_1 L_2}$$

Where L_1 and L_2 are determined as follows

Determination of L_1

From fig.14.1

$$X_{L1} = \text{voltmeter reading} / \text{ammeter reading}$$

$$X_{L1} = \omega L_1 = 2\pi f L_1$$

$$L_1 = X_{L1} / 2\pi f \text{ (Henry)}$$

Determination of L_2

From fig 14.2

$$X_{L2} = \text{Voltmeter reading} / \text{Ammeter reading}$$

$$X_{L2} = \omega L_2 = 2\pi f L_2$$

$$L_2 = X_{L2} / 2\pi f \text{ (Henry)}$$

Determination of Leq

From fig 14.3

$$X_{Leq} = \text{Voltmeter reading} / \text{Ammeter reading}$$

$$X_{Leq} = \omega L_{eq} = 2\pi f L_{eq}$$

$$L_{eq} = X_{Leq} / 2\pi f \text{ (Henry)}$$

14.6 TABULAR COLUMN:

For XL1

S. No.	Voltmeter Reading	Ammeter Reading	XL1 =V/I
1			
2			
3			
4			

For XL2

S. No.	Voltmeter Reading	Ammeter Reading	XL2 =V/I
1			
2			
3			
4			

For Xeq

S. No	Voltmeter Reading	Ammeter Reading	XLeq =V/I
1			
2			
3			
4			

14.7 RESULT:

14.8 PRE LAB VIVA QUESTIONS:

1. What is self inductance?
2. What is mutual inductance?
3. Define coefficient of coupling.
4. What is the formula for coefficient of coupling?
5. Define self induced emf.
6. Define mutually induced emf.

14.9 LAB ASSIGNMENT:

1. Derive the expression between self inductance of two coils, mutual inductance between them and coefficient of coupling.
2. State and explain Faraday's law of electromagnetic induction.
3. Two coils of self inductances L_1 and L_2 are connected in series and M is the mutual inductance between them, derive the expression for the net inductance of the coil.

14.10 POST LAB VIVA QUESTIONS:

1. Using dot convention, discuss the coupling in a simple magnetic circuit?
2. What is statically induced emf and dynamically induced emf?
3. Compare electric and magnetic circuit.

4. What is Lenz's law?

