



JAIPUR INSTITUTE OF TECHNOLOGY GROUP OF
INSTITUTIONS, JAIPUR

LIST OF EXPERIMENTS

1. To verify KVL and KCL
2. Verification of Network Theorems.
3. Study of diode characteristics. Study of phenomenon of resonance in RLC series circuit.
4. Measurement of power in a three phase circuit by two wattmeter Method.
5. Measurement of efficiency of a single phase transformer by load test.
6. Determination of parameters and losses in a single phase transformer by OC and SC test.
7. Study of characteristic of DC Motor.

8. DC generator characteristics.
9. Speed control of dc shunt motor.
10. Study running and reversing of a three phase induction motor.
11. Study of a single phase energy meter.

Experiment No-1 Theory and Concept

Objective: TO VERIFY KCL AND KVL.

Apparatus: - DC NETWORK KIT AND CONNECTING WIRES.

Theory: KCL AND KVL are used to solve the electrical network, which are not solved by the simple electrical formula.

KCL : It states that in any electrical network the algebraic sum of currents meeting at a point is zero. Consider the case of few conductors meeting at a point A in the fig. Assuming incoming currents to be positive and the outgoing currents to be negative. $I_1 + (-I_2) + (-I_3) + I_4 + (-I_5) = 0$

KVL: It states that the algebraic sum of product of current and resistance in each of the conductors in any closed path in a network plus the algebraic sum of the e.m.f. in the closed path is zero.

$$\sum IR + \sum E.M.F. = 0$$

CIRCUIT DIAGRAM:

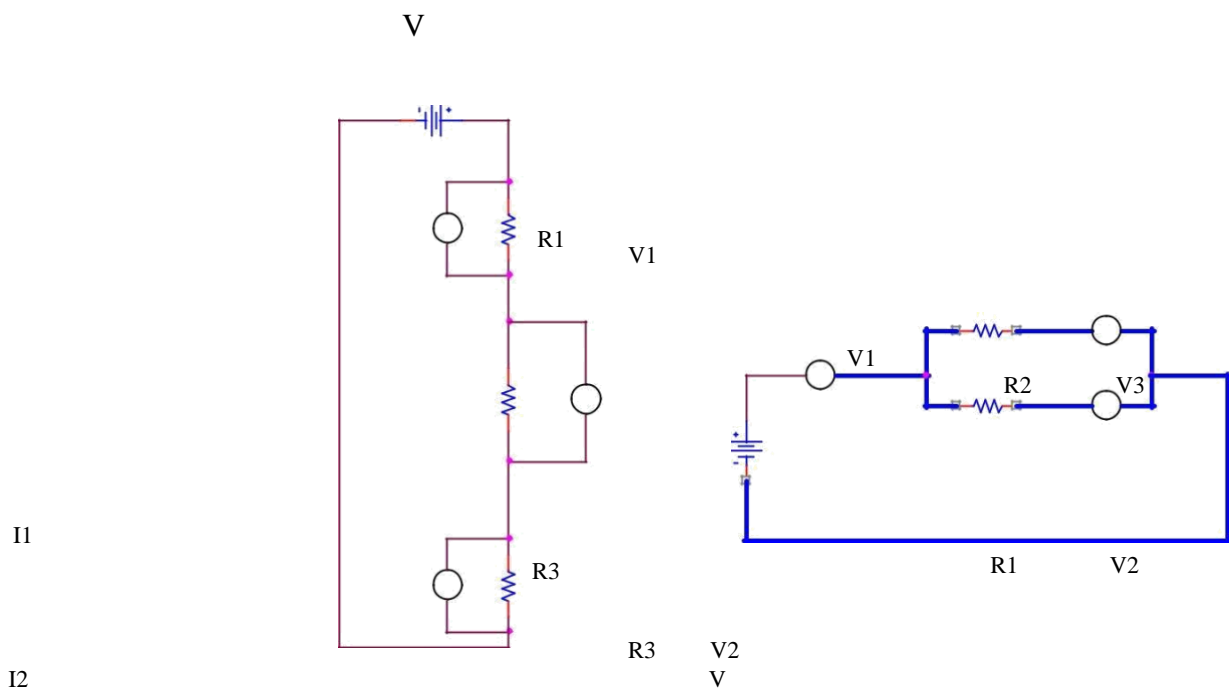

V3

KVL

KCL

PROCEDURE:

KCL:

1. Make the connection according to the ckt diagram
 2. Set the three rheostats to their max value.
 3. Switch on the power supply
 4. Change the setting of the rheostats to get different readings in all the three ammeters.
 5. Measure the current in the three ammeters
 6. Check that at every time current in the main branch is equal to the sum of currents in the two branches. repeat the setting of the rheostat
 7. Switch off the power supply. **KVL:**
1. Connect the circuit as per the circuit diagram
 2. Switch on the power supply
 3. Note down the readings of the voltmeters
 4. Change the value of the rheostat and repeat the step several times and switch off the power supply.
 5. **OBSERVATION TABLE:**

KCL:

S.NO	Applied Voltage (V)	I_1 (mA)	I_2 (mA)	$I_1 + I_2$ (mA)	I	Remark

KVL:

S.NO	Applied Voltage (V)	V_1 (Volts)	V_2 (Volts)	V_3 (Volts)	$V = V_1 + V_2 + V_3$	Remark

RESULT:

1. The incoming current is found to be equal to the outgoing current
2. The total input voltage is equal to the total voltage drop in the ckt.

DISCUSSION:

KCL AND KVL are very important in solving the circuits where direct formula can't be applied.

PRECAUTIONS:

1. All connections should be tight and correct.
2. Switch off the supply when not in use.
3. Reading should be taken carefully.

QUESTIONS/ANSWERS:

Q.1 what is the statement of Kirchhoff's first law?

A. The sum of the currents entering at any junction is equal to the sum of the currents leaving the junction.

Q.2 According to Kirchhoff's second law, the algebraic sum of all IR drops and emf's in any closed loop of a network is equal to... A. It is equal to zero. Q.3 Kirchhoff's second law is related to what?

A. EMF and IR drops.

Q.4 what is the internal resistance of the ideal voltage source? A. Zero

Q.5 what is higher, the terminal voltage or the emf?

A. The emf

Q.6 What is the internal resistance of the current source ideally?

A. Infinity

Q.7 What is the active network?

A. An active network is that which contains one or more than one sources of emf. or current sources

Q.8 What is the bilateral network?

A. It is the circuit whose properties are same in either direction

Q.9 What is the difference between a node and a branch?

A. A node is a junction in the circuit where two or more than two circuit elements are connected together. The part of the network, which lies between two junctions, is called branch.

Q.10 What is the non-linear circuit?

A. The circuit whose parameters change with the change in voltage and current is called the non-linear ckt.

	Jaipur Institute Of Technology Department of Electrical & Electronics Engineering	LABORATORY MANUAL
--	---	-------------------

PRACTICAL INSTRUCTION SHEET

EXPERIMENT NO. 2

ISSUE NO. :

ISSUE DATE:

REV. NO. :

REV. DATE :

PAGE:

LABORATORY Name & Code: **PEE-101 Basic Electrical Engineering Lab**

SEMESTER: 1

Experiment No-2 Theory and Concept

AIM: TO VERIFY THEVENIN'S THEOREM.

APPARATUS: DC NETWORK KIT AND CONNECTING LEADS

THEORY: THEVENIN'S THEOREM as applied to the dc network ckt may be stated as the current flowing through a load resistance R_L connected across any two terminals A and B of a linear bilateral network is given by $V_{TH} / R_{TH} + R_L$ where V_{TH} is the open ckt voltage and R_{TH} is the internal resistance of the network from terminal A to B with all voltage sources replaced with their internal resistances and current sources with infinite resistance.

CIRCUIT DIAGRAM:

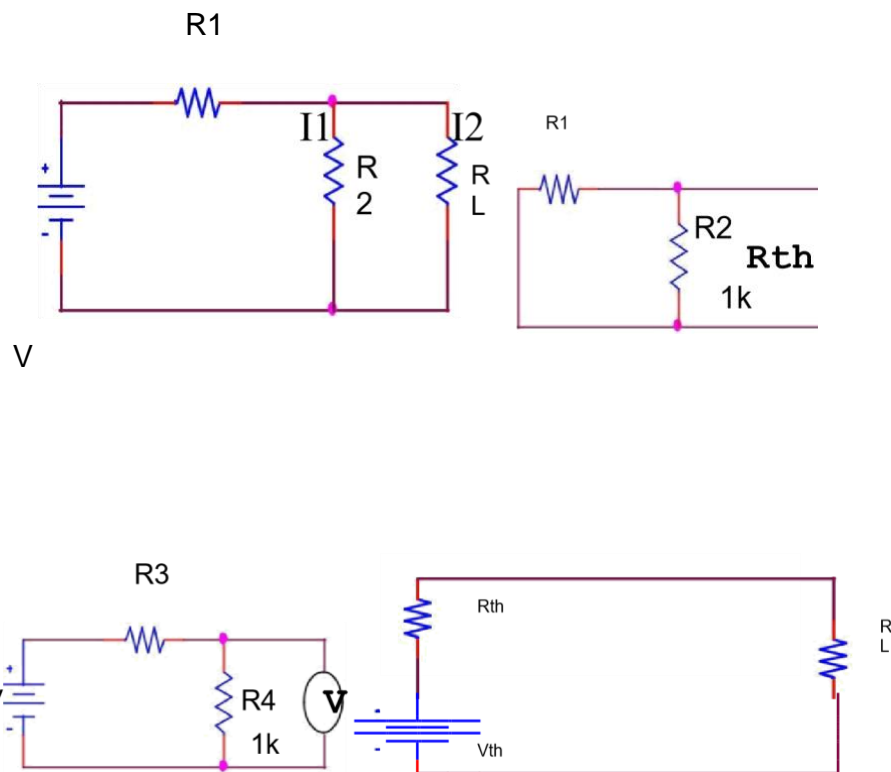

PROCEDURE:

1. To find the current flowing through the load resistance R_L as shown in fig. remove R_L from the ckt temporarily and leave the terminals A and B open circuited.
2. Calculate the open ckt voltage V_{TH} which appears across terminal A and B. $V_{TH} = I \cdot R_{TH}$

This is called Thevenin's voltage.

3. Now calculate $R_{TH} = R_1 R_2 / (R_1 + R_2)$. This is called Thevenin's resistance.
4. Calculate $I_L = V_{TH} / (R_L + R_{TH})$.
5. $V_{TH} = E R_2 / (R_1 + R_2)$.

OBSERVATION TABLE:

SR.NO	APPLIED VOLTAGE (volts)	V_{TH} (volts) Theo.	V_{TH} (volts) Pract.	R_{TH} (Ohms)	I_L (mA) Pract.	I_L (mA) Theo.	RESULT

RESULT: THEVENIN'S THEOREM has been verified.

DISCUSSION: In Thevenin's equivalent circuit Thevenin's equivalent voltage is in series with Thevenin's resistance and the load resistance.

PRECAUTIONS:

1. Switch off the supply when not in use.
2. Reading should be taken carefully.
- 3.

All connections should be tight and correct.

QUESTIONS/ANSWERS

Q.1 To what type of circuit Thevenin's theorem is applicable

A. Linear and bilateral

Q.2 What is the use of Thevenin's theorem?

A. To convert the complex ckt into a voltage source and a series resistance

Q.3 How R_{TH} is connected with the ckt?

A. In series

Q.4 How is R_{TH} connected with the load resistance?

A. In series

Q.5 What modification is done in galvanometer to convert it into a ammeter?

A. A large resistance in parallel

Q.6 What modification is done in the galvanometer to convert it into a voltmeter?

A. A series resistance

Q.7 Resistance is a n active element or the passive?

A. Passive

Q.8 How will you calculate the RTH?

A. The resistance between the two terminals

Q.9 In place of current source, what is placed while calculating RTH?

A. Replace current source by open ckt

Q.10 In place of voltage source which electrical parameters is placed?

A. A short ckt.

	JAIPUR INSTITUTE Of Technology Department of Electrical & Electronics Engineering		LABORATORY MANUAL
	PRACTICAL INSTRUCTION SHEET		
	EXPERIMENT NO. 3	ISSUE NO. :	ISSUE DATE:
	REV. NO. :	REV. DATE :	PAGE:

Experiment No-3 Theory and Concept

AIM: TO VERIFY NORTON'S THEOREM.

APPARATUS: DC NETWORK KIT, CONNECTING LEADS.

THEORY: Norton's theorem replaces the electrical network by an equivalent constant current source and a parallel resistance. Norton's equivalent resistance $R_N = R_1 * R_2 / (R_1 + R_2)$ Actual load current in the circuit I_{L1} Theoretical load current $I_{L2} = I_{SC} * R_N / (R_N + R_L)$, I_{SC} is the short circuit current.

CIRCUIT DIAGRAM:

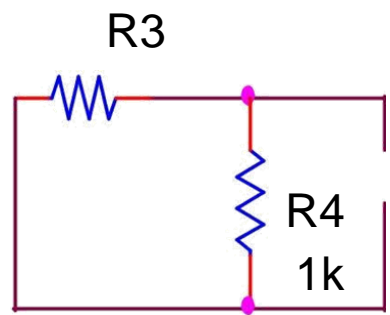
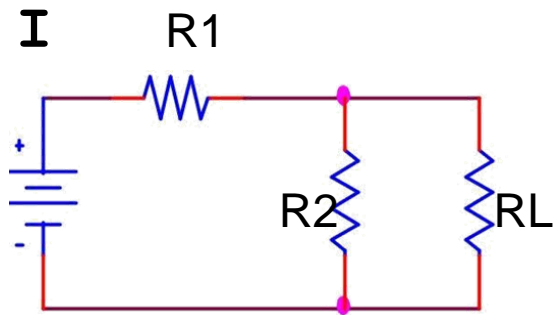

V_N

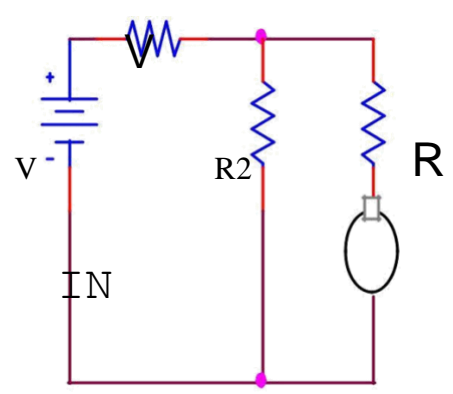
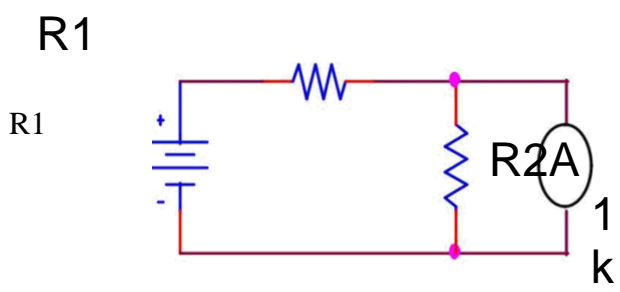

V

A

OBSERVATION TABLE:

SR.NO.	APPLIED VOLTAGE (volts)	I_N (mA)	R_N (Ω)	I_{L1} (mA)	I_{L2} (mA)	<u>ERROR</u> I_{L1} - I_{L2}	<u>RESULT</u>

PROCEDURE :

1. Connect the ckt as per the ckt diagram
2. Remove the load resistance
3. Find the Norton's resistance R_N
4. Measure the Norton's current I_N
5. Now measure the current in the load resistance directly
6. Find out the current in the load
7. Using formula find out the current in the load resistance
8. Verify that these two are equal.

RESULT : Norton's theorem is verified

DISCUSSION:In NORTON'S equivalent circuit the Norton's current source is in parallel with NORTON'S resistance and the load resistance.

PRECAUTIONS:

1. All connections should be tight and correct.
2. Switch off the supply when not in use.

Reading should be taken carefully

QUESTIONS/ANSWERS:

Q.1 To what type of network Norton's theorem applicable?

A. Two terminal linear network containing independent voltage and current sources.

Q.2 How is R_N connected to

I_N ? **A.** In the parallel

Q.3 What is placed in place of voltage sources while calculating the

R_N ? **A.** Their internal resistance replaces these.

Q.4 Give an example of unilateral ckt?

A. Diode rectifier

Q.5 What is unilateral ckt?

A. Whose characteristics changes with the change in direction of operation

Q.6 Give one example of the bilateral n/w?

A. Transmission lines

Q.7 What is the limitation of Ohm's law?

A. Provided physical conditions do not change

Q.8 What is the reason that ground pin are made of greater diameter in the plugs?

A. $R = \rho L/A$

Q.9 Where is the voltage divider rule applicable?

A. Two resistance in series

Q.10 Where is the current divider rule applicable?

A. When there are two resistances in parallel.

	Jaipur Institute Of Technology Department of Electrical & Electronics Engineering	LABORATORY MANUAL
--	---	-------------------

	PRACTICAL INSTRUCTION SHEET		
	EXPERIMENT NO. 4	ISSUE NO. :	ISSUE DATE:
	REV. NO. :	REV. DATE :	PAGE:
LABORATORY Name & Code: PEE-101 BEE Lab			SEMESTER: I

Experiment No-4 Theory and Concept

OBJECTIVE: TO STUDY FREQUENCY RESPONSE OF SERIES R-L-C CIRCUIT AND DETERMINE RESONANCE FREQUENCY.

APPARATUS: CRO, AUDIO FREQUENCY GENERATOR, MULTIMETER AND CONNECTING LEADS.

THEORY: In the series resonance circuit , the net reactance

$$X = X_L - X_C$$

So impedance of the ckt

$$Z = \sqrt{R^2 + (X_L - X_C)^2}$$

at the resonance frequency the capacitive reactance becomes equal to the inductive reactance.

$$X_L = X_C$$

$$C \omega_0 L = 1/\omega_0 \quad f_0 = 1/2\pi\sqrt{LC}$$

CIRCUIT DIAGRAM:

50uH

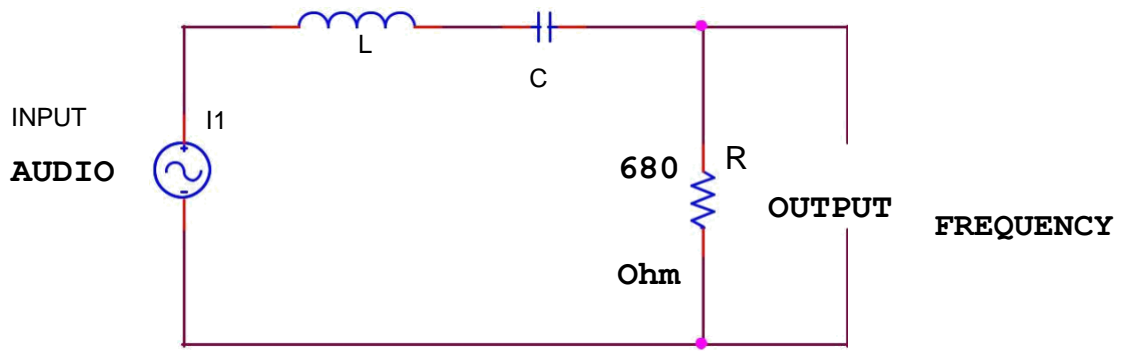

PROCEDURE:

1. Make the connections shown in fig.
2. Frequency is given by audio frequency generator.
3. Change the frequency and note the reading carefully.
4. At certain frequency the voltage becomes maximum after which the voltage decreases. This is the resonance frequency.
5. Plot a graph between frequency and voltage.
- 6.

OBSERVATION TABLE:

S.NO	FREQUENCY (KHz)	VOLTAGE (volts)

GRAPH:

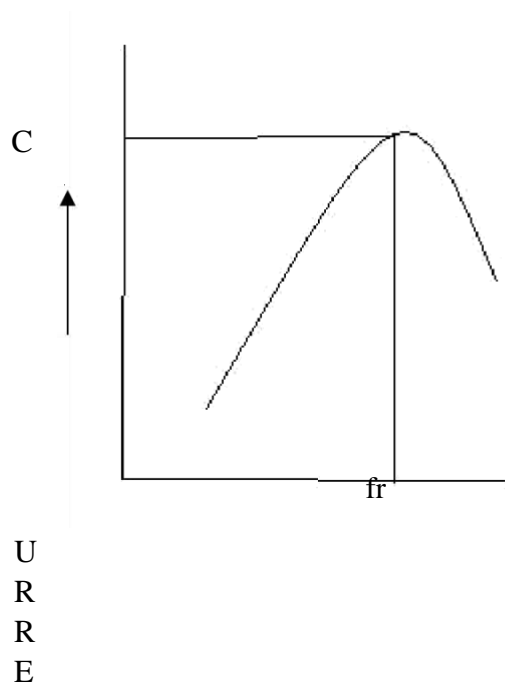

FREQUENCY



RESULT: The resonance frequency is found to be.....kHz.

DISCUSSION: Impedance is minimum at resonance frequency.

PRECAUTIONS:

- 1 All connections should be tight and correct.
- 2 Switch off the supply when not in use.
- 3 Reading should be taken carefully.

	Jaipur Institute Of Technology Department of Electrical & Electronics Engineering		LABORATORY MANUAL
	PRACTICAL INSTRUCTION SHEET		
	EXPERIMENT NO. 5	ISSUE NO. :	ISSUE DATE:
	REV. NO. :	REV. DATE :	PAGE:
LABORATORY Name & Code: PEE-101 BEE lab			SEMESTER: I

Experiment No-5 Theory and Concept

OBJECTIVE: - MEASUREMENT OF POWER IN A THREE PHASE SYSTEM BY TWO WATTMETER METHOD

APPARATUS REQUIRED: - THREE PHASE VARIABLE LOAD, AMMETERS 0-10 A, MI, 2NOS, WATTMETERS 0-5 A, 300V, 2 NOS, VOLTMETER 0-300V, MI

THEORY: - Surprisingly, only two single phase wattmeter's are sufficient to measure the total power consumed by a three phase balanced circuit. The two wattmeters are connected as shown in figure. The current coils are connected in series with two of the lines .The pressure (or voltage) coils of the two wattmeter's are connected between that line and reference.

CIRCUIT DIAGRAM:-

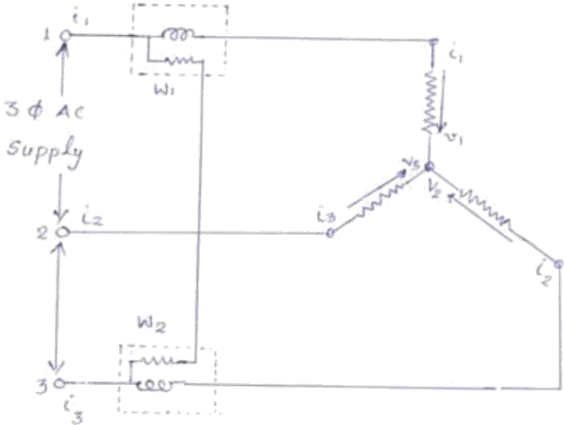

PROCEEDURE:-

1. Connect the circuit as shown in figure.
2. Keep the three phase variac at its zero position .
3. Switch on the main supply.
4. Increase the voltage supplied to the circuit by changing the positions of variac so that all the meters give readable deflection.
5. Note down readings of all the meters

OBSERVATION TABLE:-

Sr.N o	V	I	W1	W2	P= W1 + W2

PRECAUTIONS :

1. Connections should be tight.
2. Take the readings carefully.
3. Switch off the circuit when not in use.

QUESTIONS/ANSWERS:-

Q.1. How many coils are there in a single in a single phase wattmeter?

A. In general there are two coils in the wattmeter. One coil is known as current coil and other coil is known as pressure coil or voltage coil.

Q.2. What do you understand by phase sequence in reference to 3-phase circuits?

A. Phase sequence in three phase circuits means the order in which the phase voltages attain their respective maximum positive voltages.

Q.3 What is the phase sequence of a 3-phase system in general? A. The

phase sequence of a three phase system is R,Y, B.

Q.4 How the phase sequence of a three phase system can be changed?

A. If the connections of any two phases are interchanged, the phase sequence can be changed.

Q.5 Is the method used in this experiment applicable to unbalanced

loads? A. Yes, we can use this method for unbalanced loads.

Q.6 Can you measure reactive power in a three phase circuit using this method? A. Yes the reactive power is given by the relation.

$$Q=\sqrt{3} (W_1 - W_2)$$

	Jaipur Institute Of Technology Department of Electrical & Electronics Engineering		LABORATORY MANUAL
	PRACTICAL INSTRUCTION SHEET		
	EXPERIMENT NO. 6	ISSUE NO. :	ISSUE DATE:
	REV. NO. :	REV. DATE :	PAGE: 16
LABORATORY Name & Code: PEE-101 BEE lab			SEMESTER:

Experiment No-6 Theory and Concept

AIM: TO PERFORM THE DIRECT LOAD TEST ON THE TRANSFORMER AND PLOT THE CURVE BETWEEN EFFICIENCY AND VOLTAGE.

APPARATUS: AUTO TRANSFORMER, SINGLE PHASE DOUBLE WOUND TRANSFORMER, AMMETER, VOLTMETER.

THEORY: The ac voltage is applied to the primary coil, the ac current in the primary coil gives rise to flux change. The change of flux induces emf in the secondary coil due to mutual induction.

We can calculate the efficiency by using voltmeter and ammeter since we are using resistive load.

CIRCUIT DIAGRAM:

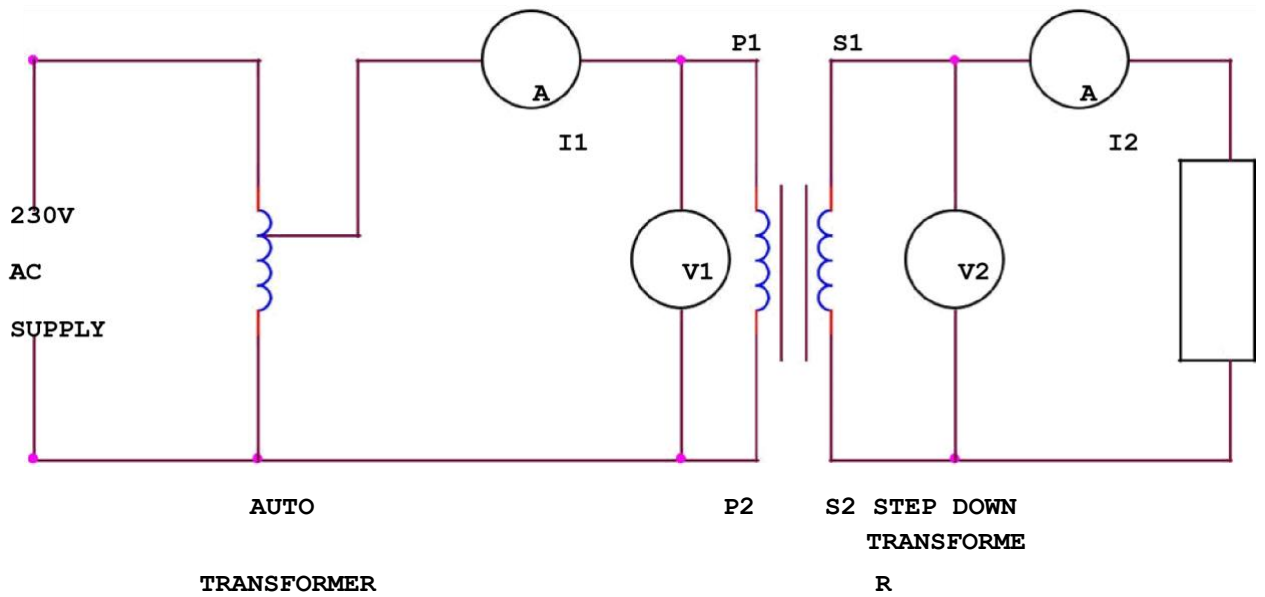

PROCEDURE:

1. Connect the ckt as shown in fig.
2. Take the readings of I1 and V1 for primary
3. Take the readings of I2 and V2 for secondary
4. Calculate the efficiency of the transformer using the formula
5. Efficiency= output power/input power.

OBSERVATION TABLE:

S.NO	I1 (mA)	V1 (volts)	I2	I2	Efficiency= V2 I2/ V1 I1

GRAPH:

The efficiency increases with the increase in voltage and becomes maximum at a particular voltage and after that it decreases.

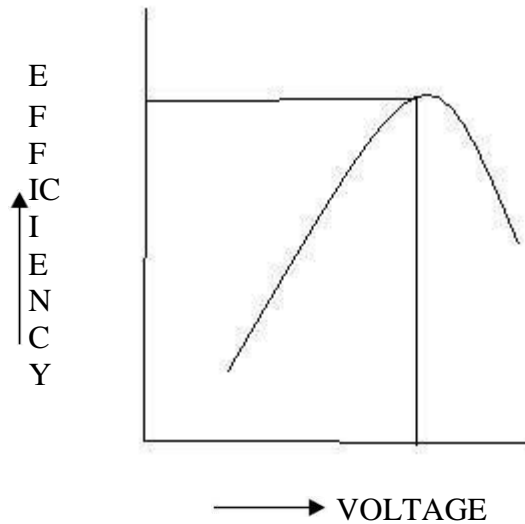

RESULT:

The efficiency of the single-phase transformer comes out to be.....

DISCUSSION: Mutual induction is the basic principle in the transformer. Direct load test is carried out to find out the efficiency of the transformer.

PRECAUTIONS:

1. All connections should be tight and correct.
2. Switch off the supply when not in use.
3. Reading should be taken carefully.

QUESTIONS/ANSWERS:

Q.1 What is the effect on the frequency in the transformer?

A. No change

Q.2 What is the medium for the energy conversion from the primary to secondary in the transformer? **A.** By the flux.

Q.3 What is the main reason for the generation of harmonics in the transformer? **A.** Saturation of the core

Q.4 Why are the ferrite cores used in the high frequency transformer?

A. High resistance

Q.5 What type of winding is used in the 3-phase shell type transformer?

A. Sandwich type

Q.6 What is increased in step up transformer?

A. Voltage

Q.7 What is the effect on voltage in step down transformer?

A. Voltage is decreased

Q.8 What is the formula of efficiency?

A. Output energy/input energy

Q.9 What is the function of bushings in the transformer?

A. To make the external connections

Q.10 What is the principal of transformer? A.

Mutual induction.

	Jaipur Institute Of Technology Department of Electrical & Electronics Engineering		LABORATORY MANUAL
	PRACTICAL INSTRUCTION SHEET		
	EXPERIMENT NO. 7	ISSUE NO. :	ISSUE DATE:
	REV. NO. :	REV. DATE :	PAGE:
LABORATORY Name & Code: PEE-101 BEE Lab			SEMESTER: I

Experiment No-7 Theory and Concept

OBJECTIVE: To perform short circuit test on a single phase transformer to calculate:

1. The copper loss of the transformer.

Apparatus Required:

1. A.C Wattmeter - 1 nos. (0- 75 W)
2. A.C Voltmeter - 1 nos. (0-300 V)
3. A.C ammeter - 1 nos. (0-25 A)

4. Variac: 230 V, 10 A, 50 Hz, 1-Phase
5. Transformer (1phase, 50 Hz)
6. Connecting wires

Circuit Diagram

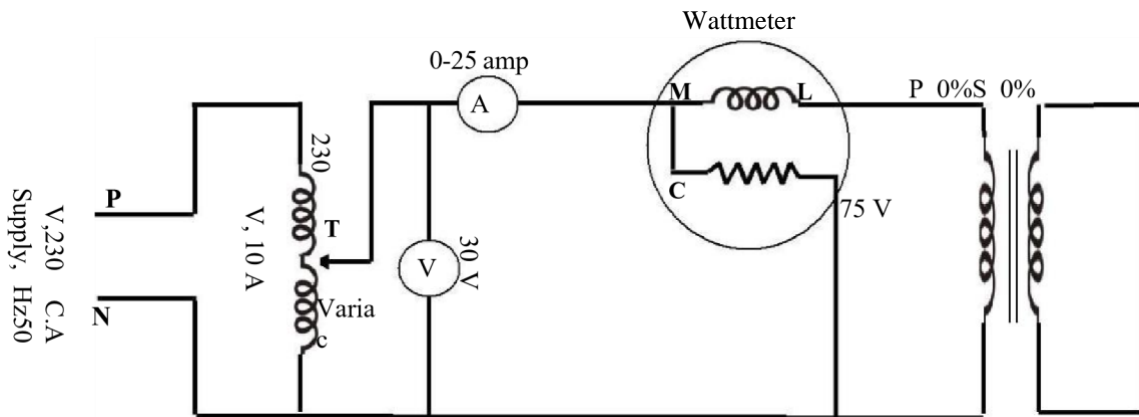

Theory:

$$W_{sc} = R_{01} I_{sc}^2$$

$$I_{sc} = \frac{V_B}{\sqrt{Z_{01}^2 + R_{01}^2}}$$

$$W_{sc} = R_{01} \left(\frac{V_B}{\sqrt{Z_{01}^2 + R_{01}^2}} \right)^2$$

$$I_{sc} = \frac{V_B}{\sqrt{Z_{01}^2 + R_{01}^2}}$$

$$X_{01} = \sqrt{Z_{01}^2 - R_{01}^2}$$

$$R_{01} = \frac{W_{sc}}{I_{sc}^2}$$

Procedure:

1. Make the connections as per the circuit diagram.
2. Make sure that the secondary side of transformer is shorted.
3. Keep the variac at zero position before switch on the supply.
4. Switch on A.C supply.
5. By varying the variac apply full load current to the transformer and note the reading of voltmeter, wattmeter and ammeter.
6. Keep the variac at zero position and switch of supply.

Tabulation:

Sl.No.	Voltmeter Reading(V)	Ammeter Reading (A)	Wattmeter Reading W)
1			

Calculation:

Calculate the multiplying factor (M.F) of the wattmeter.

$M.F = \frac{(\text{Rating of C.C}) * (\text{Rating of P.C}) * \cos\phi}{(\text{Wattmeter Rating in})}$ Copper

loss = W_{sc} (in Watts) = Wattmeter Reading * M.F

Short circuit current = Ammeter reading = I_{sc}

Voltmeter Reading = V_{sc}

Copper loss = Wattmeter Reading = W_{sc}

Calculate the values of R_{01} , X_{01} , Z_{01} .

Precautions:

1. All the connections should be tight and clean.
2. Special care should be taken while selecting the ranges of the meters for conducting short-circuit test.
3. While conducting the short-circuit test, the voltage applied should be initially set at zero, and then increase slowly. If a little higher voltage than the required voltage be applied (by mistake), there is a danger of transformer being damaged.

Questions:

1. Why transformer rating is in KVA?
2. What type of losses occur in the primary and secondary windings of a transformer when it is in service?
3. How do copper losses vary with load on the transformer?
4. Which parameters of the equivalent circuit of a transformer can be found through shortcircuit test ?

	Jaipur Institute Of Technology Department of Electrical & Electronics Engineering		LABORATORY MANUAL
	PRACTICAL INSTRUCTION SHEET		
	EXPERIMENT NO. 8	ISSUE NO. :	ISSUE DATE:
	REV. NO. :	REV. DATE :	PAGE:
LABORATORY Name & Code: PEE-101 BEE Lab			SEMESTER: I

Experiment No-8 Theory and Concept

Aim of the Experiment: To perform open circuit test on a single phase transformer to calculate:

2. The equivalent circuit parameters with respect to primary side of the transformer.
3. The open circuit loss or core loss/iron loss of the transformer. **Apparatus**

Required:

1. A.C Wattmeter - 1 nos. (0- 250 W)
2. A.C Voltmeter - 1 nos. (0-250 V)
3. A.C ammeter - 1 nos. (0-2.5 A)
4. Variac: 230 V, 10 A, 50 Hz, 1-Phase

5. Transformer (1phase, 50 Hz)
6. Connecting wires

Circuit Diagram

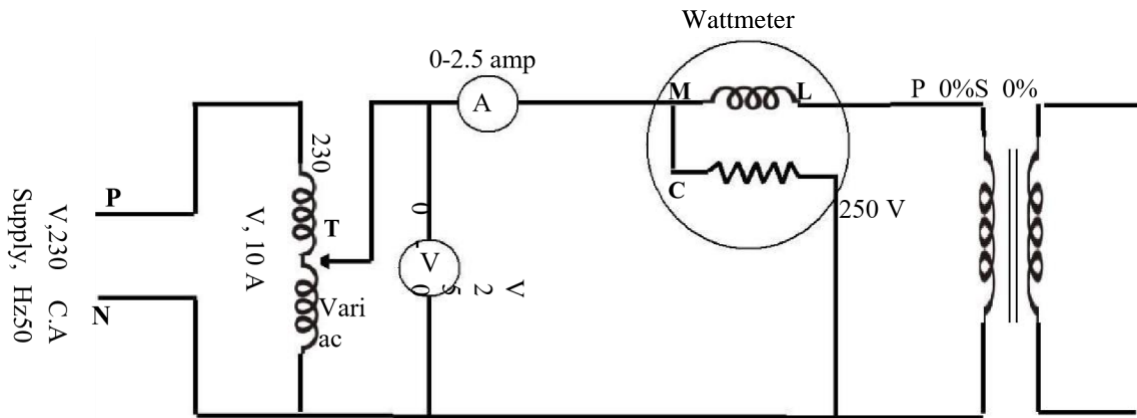

Procedure:

9. Make the connections as per the circuit diagram.
10. Make sure that the secondary side of transformer is open.
11. Keep the variac at zero position before switch on the supply.
12. Switch on A.C supply.
13. By varying the variac apply full supply voltage i.e. 230V to the primary of the transformer and note the reading of voltmeter, wattmeter and ammeter.
14. Keep the variac at zero position and switch of supply.
- 15.

Tabulation:

S.NO	Voltmeter Reading (v)	Ammeter Reading (A)	Wattmeter Reading(W)

Calculation:

Calculate the multiplying factor (M.F) of the wattmeter.

$$M.F = \frac{(\text{Rating of C.C}) \times (\text{Rating of P.C}) \times \cos \phi}{\text{Wattmeter Reading}}$$

$$\text{Iron loss} = W \text{ (in Watts)} = \text{Wattmeter Reading} \times M.F$$

$$\text{No load current} = \text{Ammeter reading} = I_0$$

$$\text{Supply Voltage} = \text{Voltmeter Reading} = V_1$$

Precautions:

1. All the connections should be tight and clean.
2. Special care should be taken while selecting the ranges of the meters for conducting open-circuit test.

Questions:

1. When a transformer is energized what types of losses occur in the magnetic frame of the transformer?
2. What information can be obtained from open circuit test of a transformer?
3. Why in open circuit test HV side is always kept open?
4. What is the power factor of a transformer under no load test situation?
5. What is the magnitude of no load current as compared to full load current?

	Jaipur Institute Of Technology Department of Electrical & Electronics Engineering		LABORATORY MANUAL
	PRACTICAL INSTRUCTION SHEET		
	EXPERIMENT NO. 9	ISSUE NO. :	ISSUE DATE:
	REV. NO. :	REV. DATE :	PAGE:
LABORATORY Name & Code: PEE-101 BEE Lab			SEMESTER: I

Experiment No-9 Theory and Concept

OBJECTIVE: To Study the speed control of D.C. Shunt motor by- (i) Field control method.

(ii) Armature control Method.

APPARATUS USED:

Sl. No.	Equipment	Type	Specification	Quantity
1.	DC Shunt motor	DC	5-HP, 1500 rpm, 16.7 amp, 220 V	1
2.	Tachometer	Digital	(0-10000) r. p. m.	1
3.	Voltmeter	MC	(0-300) volts	1
4.	Ammeter	MC	(0-1/2) A(0-5/10) A	1 each
5.	Rehostat	Single Tube	260Ω, 1.2 A	1
6.	Rehostat	Single Tube	(0-2000) rpm	1

THEORY:

DC Motor:

A machine that converts DC electrical power into mechanical power is known as DC Motor. It has been seen that a.c. Motors are invariably used in the the industry for the conversion of electrical power into mechanical power, but at the places where wide range of speed and good speed regulation is required such as in ELETRIC TRACTION, DC motor has to be applied.

Working Principle:

Its working depends upon the basic principle that when a current carrying conductor is placed in the magnetic field, a force is exerted on it and torque develops.

Types of DC Motor:

On the basis of their field excitation, the DC Motors can be classified as:

1. Separately excited DC Motor.
2. Self excited DC Motor:
 - (i) DC Shunt Motor
 - (ii) DC Series Motor

Now, the back emf of a dc motor is given by $\Rightarrow Eb = Kp * * Wm$

Where,

$$Kp = \frac{ZP}{2\pi A}$$

Kp is constant for the given motor because a machine once designed will have constant no. Of armature conductors Z no. Of poles P and number of parallel paths, ϕ is the flux per pole and Wm is the rotational velocity (mechanical).

$$Wm = 2\pi n (\text{rad/sec})$$

Where,
$$n = \frac{Eb}{2\pi Kp\phi} (\text{r.p.s})$$

$$n = \frac{60 * Eb}{2\pi Kp\phi} (\text{r.p.m})$$

Hence, speed can be controlled by:

1. By controlling Eb through variation of Vt (terminal voltage) or Ra (Armature circuit resistance) called Armature control.
2. By controlling through variation of field voltage or field resistance called field control.

1. FIELD CONTROL METHOD:

The flux produced by the shunt winding depends upon the current flowing through it. (i.e., ϕ is directly proportional to I_{sh} & $I_{sh} = V/R_{sh}$). When a variable resistance R is connected in series with the shunt field winding as shown in fig. (1), the shunt field current ($I_{sh} = V/(R_{sh}+R)$) is reduced & hence the flux ϕ . Consequently, the motor runs at a speed higher than the normal speed (since N is directly prop. to $1/\phi$). The amount of increase in speed depends upon the value of variable resistance R.

2. ARMATURE CONTROL METHOD:-

In a shunt motor flux is constant when applied terminal voltage & shunt field resistance are constant. Therefore, speed of the motor is directly proportional to the induced emf (i.e., N is directly prop. Eb & $E_b = V - I_a * R_a$). The value of Eb depends upon the drop in the armature circuit. When a variable resistance is inserted in series with the armature as shown in the figure (2), the induced emf [$E_b = V - I_a (R_a + R)$] is reduced & hence the speed. Thus the motor runs at speed lesser than the normal speed.

This method is neither economical nor efficient as a large power ($I_a^2 \cdot R$) is wasted in control resistance R since it carries full armature current I_a .

CIRCUIT DIAGRAM:

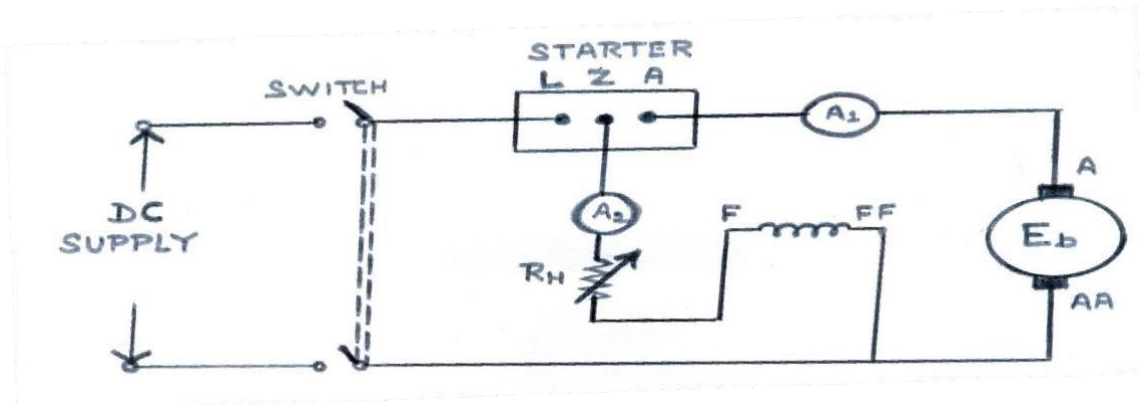
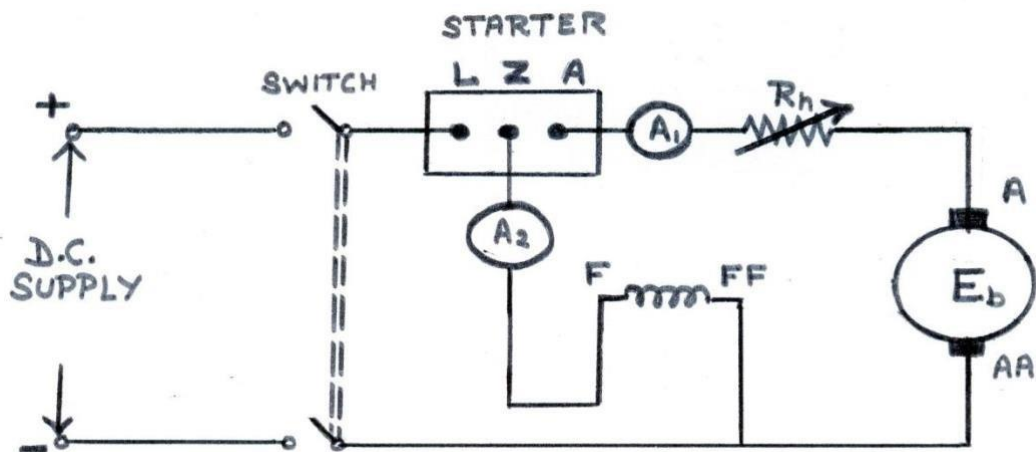

Figure (1): Field Control Method



(a) **Field Control Method:**

1. Make a proper connection as per the circuit diagram.
2. Switch on the supply and start the motor with the help of starter.
3. Now, insert the resistance in the field winding slowly.
4. Tabulate the readings of field current, voltage and the speed by tachometer in the observation table.
5. Take some more readings by varying the field resistance.
6. Plot the graph between I_f and N on the graph paper.

(b) **Armature Control Method:**

1. Make a proper connection according to the circuit diagram given in the Figure (2).
2. Start the motor.
3. For the different values of resistance, note the values from ammeter, voltmeter and tachometer and note down in the observation table.
4. Plot the graph between I_a and N on the graph paper

OBSERVATION TABLE:

Sl. No.	Field Control Method		Armature Control	
	Field Current (amp)	Speed (rpm)	Armature Current (amp)	Speed (rpm)

PRECAUTIONS:

1. All the connections should be tight.
2. Never touch the live terminal during the experiment.
3. Before changing the connection, switch off the supply properly.
4. Increase the load carefully.
5. Always use the starter of proper rating.
6. Always wear shoes when working in the lab. Avoid wearing loose clothes, hanging chains etc.
7. Make proper contact when measuring the speed with Tachometer.

RESULT:

1. The variation in speed of shunt motor, w.r.t., I_f and I_a , is shown in the observation table and plotted on the Graph.
2. From the graph we observed that speed falls down slowly as the D. C. Shunt motor is loaded from no load to full load.

	Jaipur Institute Of Technology Department of Electrical & Electronics Engineering		LABORATORY MANUAL
	PRACTICAL INSTRUCTION SHEET		
	EXPERIMENT NO. 10	ISSUE NO. :	ISSUE DATE:
	REV. NO. :	REV. DATE :	PAGE:
LABORATORY Name & Code: PEE-101 BEE Lab			SEMESTER: I

Experiment No-10 Theory and Concept

OBJECTIVE : TO PERFORM DIRECT LOAD TEST OF A D.C.SHUNT GENERATOR AND PLOT LOAD VOLTAGE V/S LOAD CURRENT

APPARATUS : D.C.SHUNT GENERATOR, D.C.AMMETER 0-20A, D.C.VOLTMETER 0-300V, VARIABLE LOAD 5 KW, RHEOSTAT 1000OHM,1.2 A

THEORY: The variation of terminal voltage V across the armature with load current is known as load characteristics or external characteristics. It is seen that the terminal voltage falls as the load current increases. This is mainly due to the ohmic drop.

CIRCUIT DIAGRM:

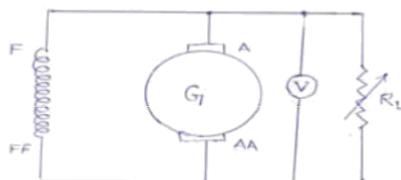

PROCEDURE:

1. Connect the circuit as shown in fig.
2. Keep the load open, adjust the field rheostat so that the emf generated corresponds to the rated voltage of the generator.

3. Note this value of the generated emf.
4. Connect the load, note the readings of ammeter which gives the load current, and the voltmeter which now, gives the value of terminal voltage V .

OBSERVATION TABLE :

S.NO	Load Current I_L	Terminal voltage (Volts)

PRECAUTIONS :

1. All the connections should be neat and tight.
2. While performing experiment, take care that the instrument readings should not exceed the ratings of the machine under test.
3. Switch off the supply when not in use

QUESTIONS/ANSWERS :-

Q.1 What is the resistance of the field winding of a d.c. shunt generator kept low?

A. If the field resistance of a d.c. generator is more than particular value(critical resistance), The generator will fail to build up the voltage. For this reason, the field resistance of a d.c. shunt generator is kept low.

Q.2 What do you understand by external characteristics of a d.c. generator?

A. The graph between the terminal voltage and load current is known as external characteristics of a d.c. generator, provided speed and field current remain constant.

Q.3 what will happen if the d.c. machine is operated below rated speed?

A. This will result in overheating due to two reasons, first, more field current has to be maintained in order to produce the rated voltage. Second, decrease in fanning action due to decrease in speed.

Q.4 What is the most important precaution in any experiment with d.c. shunt motor?

A. Before switching on d.c. supply, a sufficient resistance should be put in series with the armature of the d.c. shunt motor.

Q.5 What range of speed can you get with the field control method of speed control of d.c. shunt motor?

A. Speed higher than rated speed can be obtained by using this method.

Q.6 What range of speed can you get with the armature control method of speed control of d.c. shunt motor?

A. Speed lower than the rated speed can be obtained by the armature control method.

Q.7 Does the direction of rotation of d.c. shunt motor would get reversed if the armature current and field current both are reversed? A. No.

Q.8 If the rated speed of a d.c. shunt motor is 1440 r.p.m, which method of speed control would you suggested to obtain a speed of 1500 r.p.m? A. Field control method of speed control is suggested.

Q.9 What will happen if the d.c. shunt motor running on no-load has its shunt field winding opened accidentally?

A. The field will be reduced to only to the value of residual flux. The speed will be very high. The parts of motor may even fly apart.

Q.10 What is the most essential condition for the voltage build up for a d.c. shunt generator ? A. There should be a residual magnetism in the poles of the d.c. shunt generator.

	Jaipur Institute Of Technology Department of Electrical & Electronics Engineering	LABORATORY MANUAL
--	---	-------------------

PRACTICAL INSTRUCTION SHEET		
EXPERIMENT NO. 11	ISSUE NO. :	ISSUE DATE:
REV. NO. :	REV. DATE :	PAGE:
LABORATORY Name & Code: PEE-101 BEE Lab		SEMESTER: I

Experiment No-11 Theory and Concept

Objective:

1. To study the construction of a 3-phase induction motor
2. To study the different starting methods of 3-phase induction motors
3. To study how to reverse the direction of rotation in a 3-phase induction motor.

Theory:

Construction:

The induction motor essentially consists of two parts:

1. □
Stator □
2.
Rotor.

The supply is connected to the stator and the rotor received power by induction caused by the stator rotating flux, hence the motor obtains its name -induction motor.

The stator consists of a cylindrical laminated & slotted core placed in a frame of rolled or cast steel. The frame provides mechanical protection and carries the terminal box and the end covers with bearings. In the slots of a 3-phase winding of insulated copper wire is distributed which can be wound for 2,4,6 etc. poles.

The *rotor* consists of a laminated and slotted core tightly pressed on the shaft. There are two general types of rotors:

1. The squirrel-cage rotor, □
2. The wound (or slip ring) rotor. □

In the *squirrel-cage rotor*, the rotor winding consists of single copper or aluminium bars placed in the slots and short-circuited by end-rings on both sides of the rotor.

In the *wound rotor*, an insulated 3-phase winding similar to the stator winding and for the same number of poles is placed in the rotor slots. The ends of the star-connected rotor winding are brought to three slip rings on the shaft so that a connection can be made to it for starting or speed control.

Methods of Starting:

The most usual methods of starting 3-phase induction motors are:

- A. For slip-ring motors- rotor resistance starting
- B. For squirrel-cage motors
- C. direct-on -line starting
- D. star-delta starting
- E. Autotransformer starting.

There are two important factors to be considered in starting of induction motors:

1. The starting current drawn from the supply, and
 - The starting torque. □

The starting current should be kept low to avoid overheating of motor and excessive voltage drops in the supply network. The starting torque must be about 50 to 100% more than the expected load torque to ensure that the motor runs up in a reasonably short time.

a. Rotor resistance starting

By adding external resistance to the rotor circuit any starting torque up to the maximum torque can be achieved; and by gradually cutting out the resistance a high torque can be maintained throughout the starting period. The added resistance also reduces the starting current, so that a

starting torque in the range of 2 to 2.5 times the full load torque can be obtained at a starting current of 1 to 1.5 times the full load current.

b. Direct-on-line starting

This is the most simple and inexpensive method of starting a squirrel cage induction motor. The motor is switched on directly to full supply voltage. The initial starting current is large, normally about 5 to 7 times the rated current but the starting torque is likely to be 0.75 to 2 times the full load torque. To avoid excessive supply voltage drops because of large starting currents the method is restricted to small motors only.

To decrease the starting current cage motors of medium and larger sizes are started at a reduced supply voltage. The reduced supply voltage starting is applied in the next two methods.

c. Star-Delta starting

This is applicable to motors designed for delta connection in normal running conditions. Both ends of each phase of the stator winding are brought out and connected to a 3-phase change-over switch. For starting, the stator windings are connected in star and when the machine is running the switch is thrown quickly to the running position, thus connecting the motor in delta for normal operation.

The phase voltages & the phase currents of the motor in star connection are reduced to $1/\sqrt{3}$ of the direct-on-line values in delta. The line current is $1/3$ of the value in delta.

A disadvantage of this method is that the starting torque (which is proportional to the square of the applied voltage) is also reduced to $1/3$ of its delta value.

d. Auto-transformer starting

This method also reduces the initial voltage applied to the motor and therefore the starting current and torque. The motor, which can be connected permanently in delta or in star, is switched first on reduced voltage from a 3-phase tapped auto-transformer and when it has accelerated sufficiently, it is switched to the running (full voltage) position. The principle is similar to star/delta starting and has similar limitations. The advantage of the method is that the current and torque can be adjusted to the required value, by taking the correct tapping on

the autotransformer. This method is more expensive because of the additional autotransformer.

Reversing:

Reversing the connections to any two of the three motor terminals can reverse the direction of rotation of 3-phase induction motor **Procedure**

- B. Study the construction and the various parts of the 3-phase induction motor.
- C. For rotor resistance starting, connect the slip-ring motor as shown in FIG.1. Start the motor with full starting resistance and then decrease the resistance in steps down to zero. Take observations of the stator & rotor currents
- D. For direct-on -line starting , connect the cage motor as shown in FIG.2
- E. For star-delta starting , connect the cage motor to the terminals of the star-delta switch (FIG.3)
- F. For autotransformer starting, connect the cage motor as shown in FIG.4. Take care at starting that the "Run" switch is open and that it is not closed before the "Start" switch is opened.
- G. In each case observe the starting currents by quickly reading the maximum indication of the ammeters in the stator circuit.
- H. Reverse the direction of rotation of the motor by reversing of two phases at the terminal box. The reversal has to be made when the motor is stopped and the supply switched off.

Report:

- C. Explain the difference between a slip ring and a squirrel -cage motor. D. Discuss the merits & demerits of the various starting methods.

FIG.1 Stator

Rotor

Starter

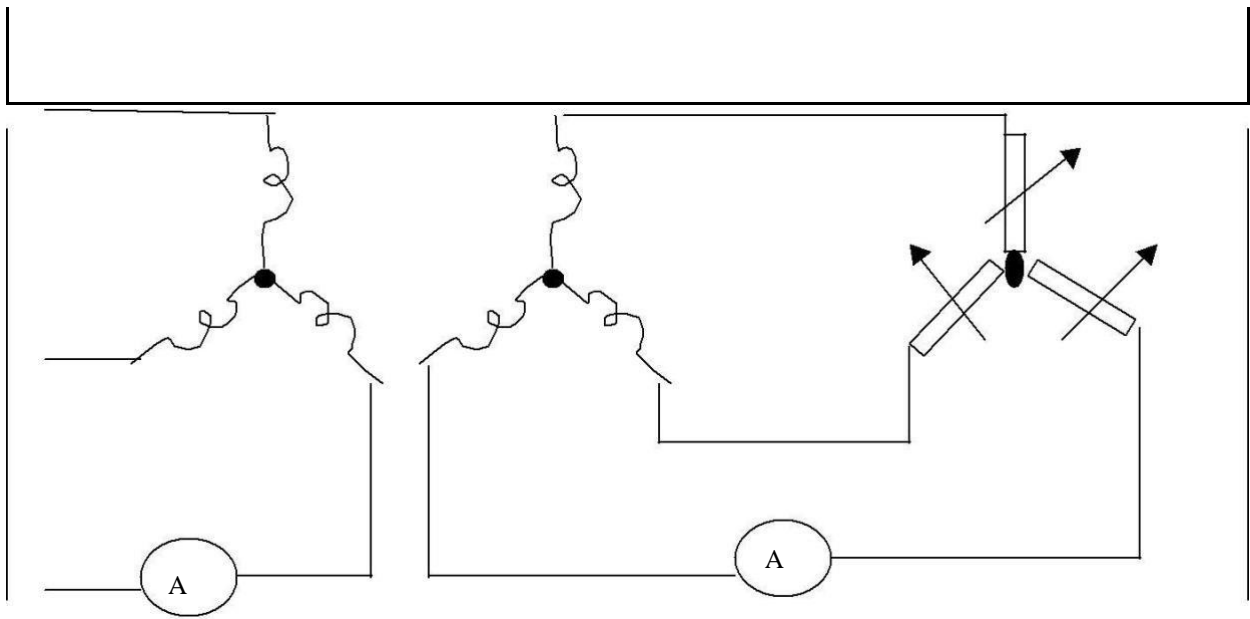

FIG.2

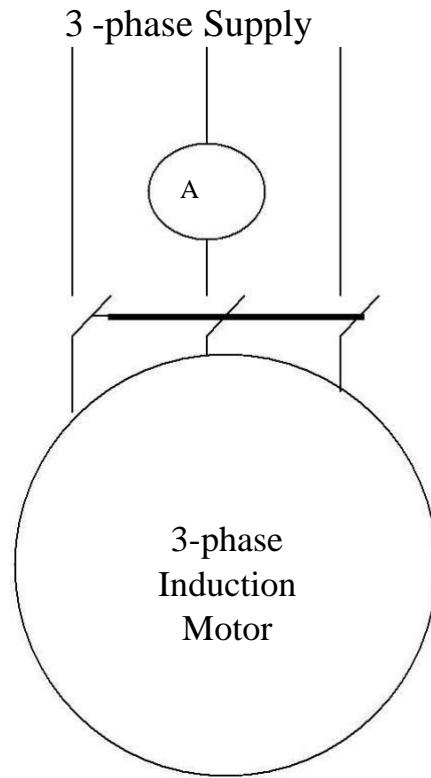

FIG.3

3 phase
Supply

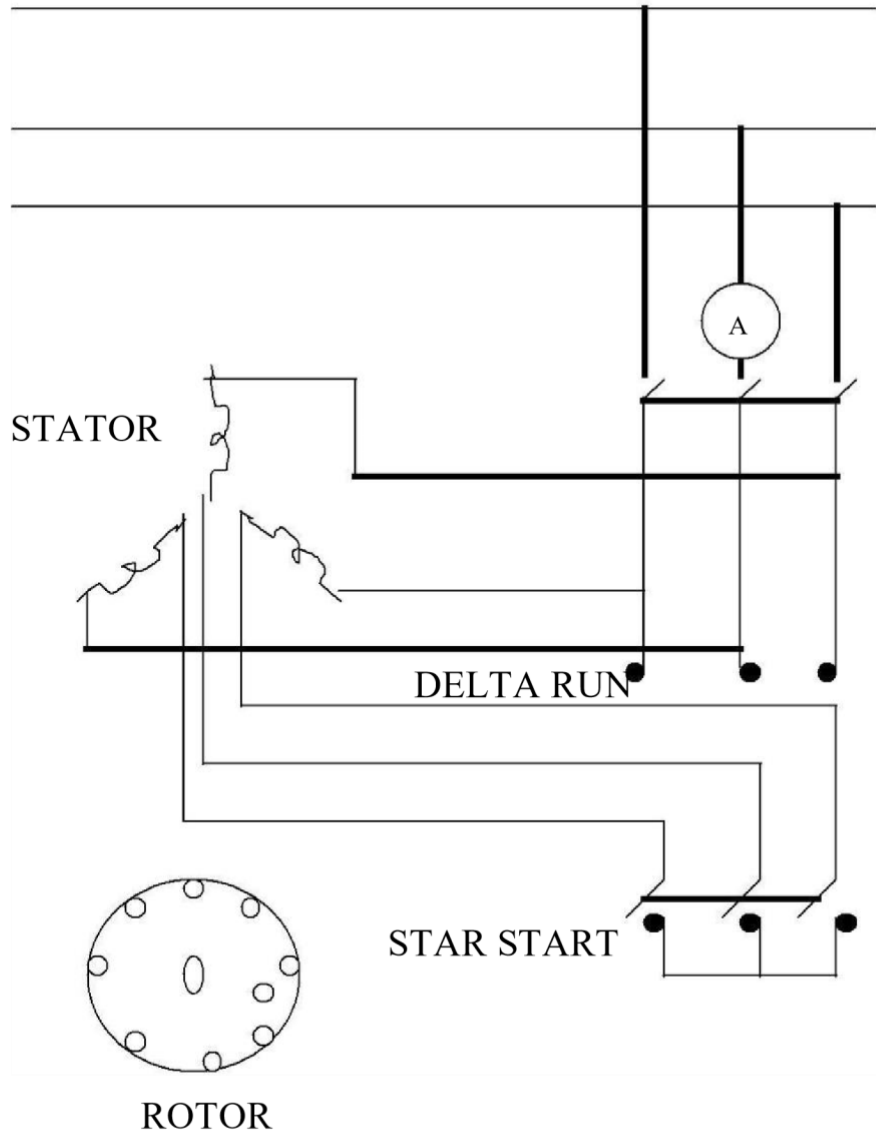
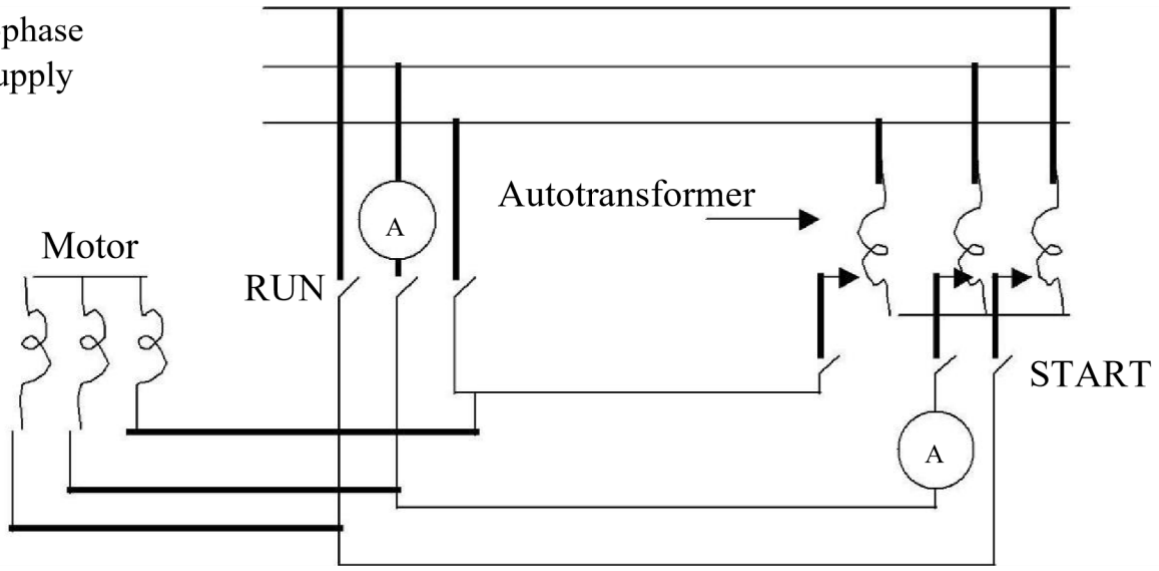

FIG.4

3-phase
Supply



	Jaipur Institute Of Technology Department of Electrical & Electronics Engineering		LABORATORY MANUAL
	PRACTICAL INSTRUCTION SHEET		
	EXPERIMENT NO. 12	ISSUE NO. :	ISSUE DATE:
	REV. NO. :	REV. DATE :	PAGE:
LABORATORY Name & Code: PEE-101 BEE Lab			SEMESTER: I

Experiment No-12 Theory and Concept

OBJECTIVE:

To measure the energy consumed in a single phase circuit and 3 phase circuit

Apparatus Required:

S.No.	Components	Range/Type	Quantity
1	Voltmeter	(0-300)V, MI type	1
2	Ammeter	(0-10)A, MI type	1
3	Wattmeter	300V, 10A, UPF/600V, 10A, UPF	½
4	Resistive load	□/ 3 □	1
5	Energy meter	□/ 3 □	1
6	Connecting wire	-	As per required

CIRCUIT DIAGRAM FOR 1 ϕ ENERGY METER

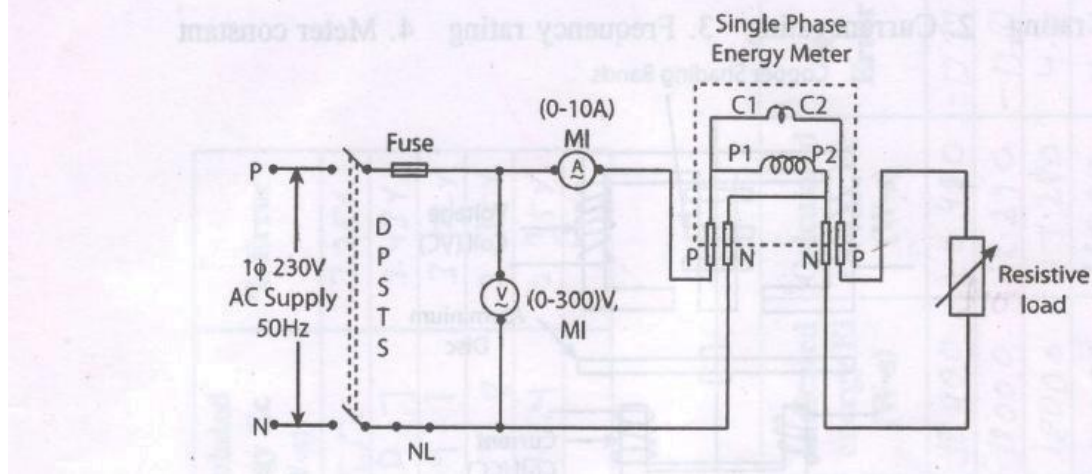

Theory:

Energy meters are interesting instruments and are used for measurements of energy in a circuit over a given period of time. Since the working principle of such instrument is based on electromagnetic induction, these are known as induction type energy meters. As shown in fig.1, there are two coils in an induction type energy meter namely current coil (CC) and voltage coil (VC), the current coil is connected in series with the load while the voltage coil is connected across the load. The aluminum disc experiences deflecting torque due to eddy current induced in it and its rotation are counted by a gear train mechanism (not shown in figure).

The rating associated with the energy meter are:

1. Voltage rating
2. Current rating
3. Frequency rating
4. Meter constant

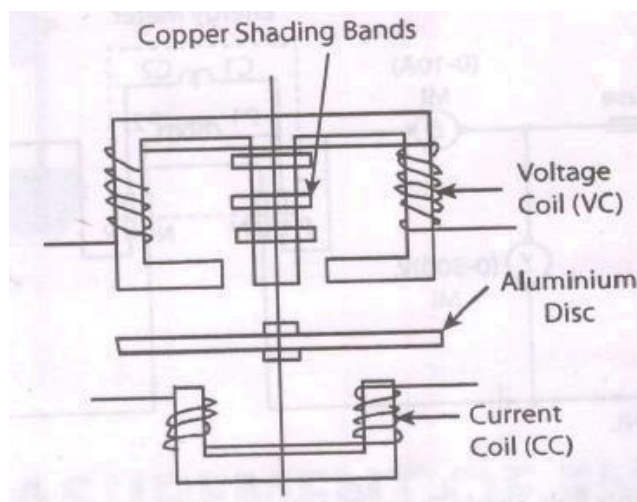

Obervation Table

S.No	Load Current (A)	Load Voltage (V)	Time Taken for n Revoltion	Indicated Energy (W1)	Calculated Energy (W2)	% Error

Formulae Used (1 Energy Meter)

1. Using energy meter constant 750 revolutions = 1kWh 1 revolution = $\frac{1}{750}$ kWh
 $\frac{1000 \times 3600}{750} = 4800$ W-s For n revolution energy is $n \times 4800$ W-s

2. Calculated energy $E = (V \times I) \times T$ W-s

Where V – load voltage

I – load current

T – Time taken for n revolution in seconds

Procedure:

1. Connect the circuit as shown in the circuit diagram.
2. Switch on the supply.
3. Load is increased in steps and each time the meter readings are noted and also the time for one revolution is also noted down.
4. Repeat the step 3 till the rated current is reached.
5. Switch off the power supply.
6. Calculate the necessary value from the given formula